

Why DC-DC Converters for High Energy Physics?

Satish Dhawan *Yale University*, Ramesh Khanna *Texas Instruments* & Richard Sumner *Cmcamac LLC*

satish.dhawan@yale.edu

R-Khanna@ti.com

rls@trsummer.com

http://shaktipower.sites.yale.edu/

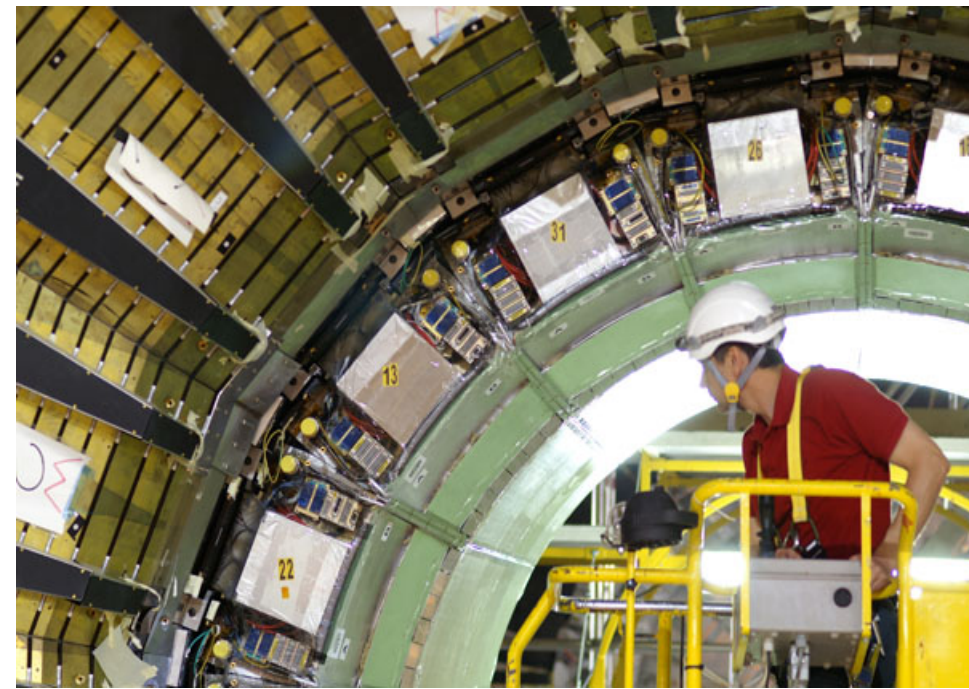
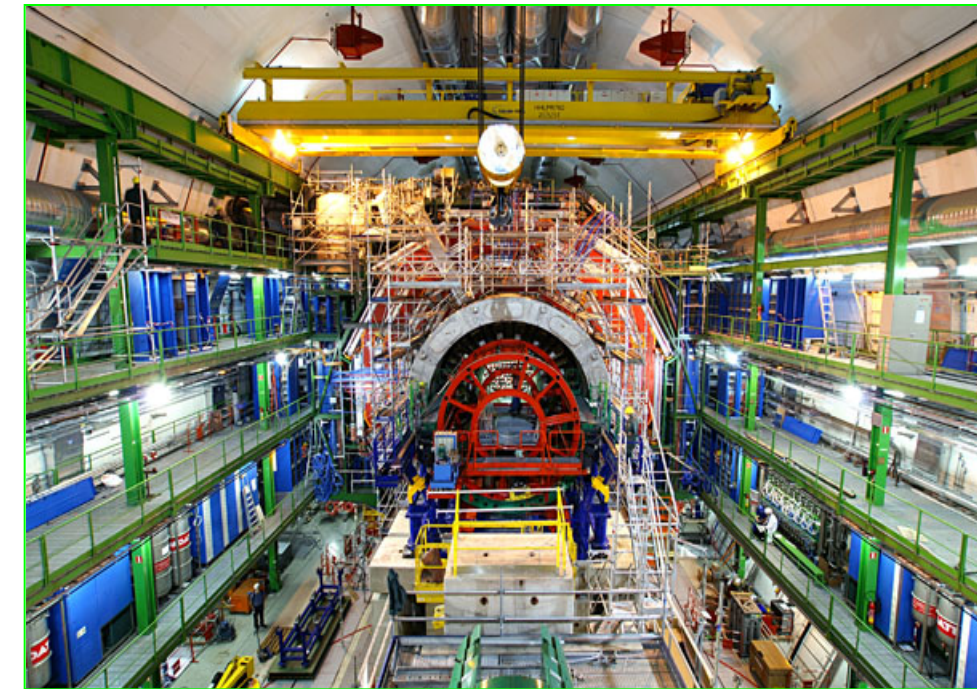

CMS Detector @ CERN Laboratory in Geneva, Switzerland

37 Countries, 155 Institutes, 2000 scientists (including about 400 students) October 2006

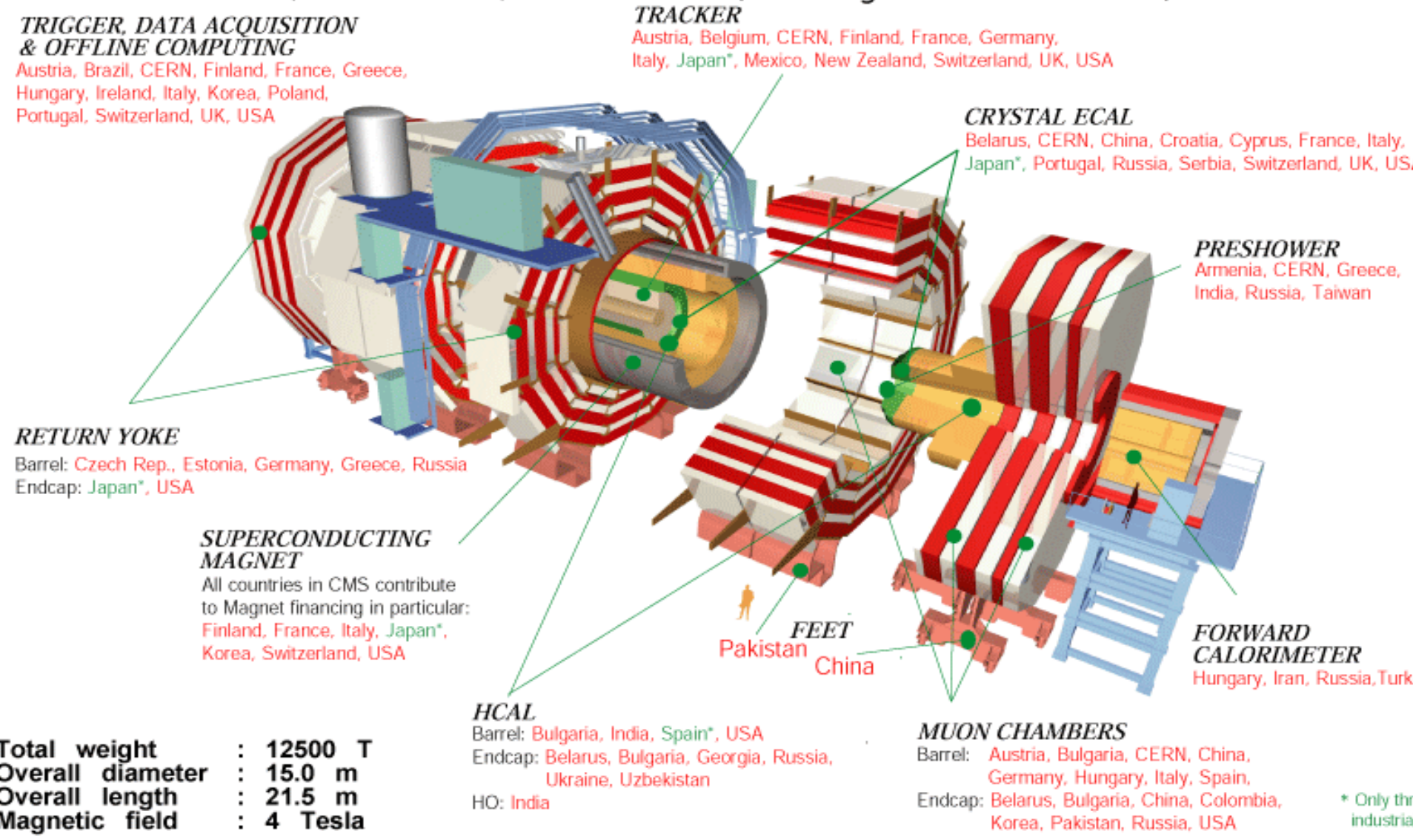

Abstract
The recent discovery of the Higgs particles at the LHC (Large Hadron Collider) was made by two very large particle detectors (CMS and ATLAS). These consist of a large magnet that is filled with and surrounded by particle detector systems. These detectors have to operate in very high magnetic fields and high radiation levels. Millions of electronic readout signal channels are needed to track, identify and measure the many particles that are produced in high energy collisions.
Yale designed and built the powering system for the ECAL (Electromagnetic Calorimeter) part of the CMS detector at LHC. The front end electronics is located inside the detector and required a total of 50,000 Amps at 2.5V. Using linear regulators (35,000 of them!) at the point of load, the power delivery efficiency was only 40% but if the cost of waste heat removal is included the efficiency is 20%. Efficient power delivery has been recognized for many years as a major issue for large, high energy physics experiments. DC to DC conversion provides a means to reduce the cable bulk and mass, and the power and heat removal requirements of experiments.
Collaborative efforts over more than five years by groups in Germany, at CERN, and elsewhere in Europe have made progress, but have also demonstrated that the DC-DC conversion requirements of high efficiency, low noise generation, small size and a large voltage reduction ratio are difficult to satisfy simultaneously.
At Yale, we are developing a two stage converter starting with 48 Volts and ending with 1.2 Volts. The intermediate bus (close to the detectors) is 5 volts and converters for 5V to 1.2V will be used at the point of load. High frequency operation is essential to allow use of air core inductors and keep physical size and mass small.

Powering The CMS detectors

Multiple Particle detector systems (tracking detector, Electromagnetic calorimeter and Hadron calorimeter) are packed like sardines inside the 15 Meter diameter (21.4 meters long) superconducting solenoid magnet. All the electronics has to operate in this uniform 4 Tesla magnetic field with no magnetic material allowed (magnetic objects will move when the magnet is switched on/off). The radiation level is the highest at the center of the detector and is reduced at larger radii due to the shielding effect of the calorimeters.
In the center of the CMS a Silicon strip detector measures the position of a particle track with an accuracy of a few 10s of microns. Particles (protons, muons, etc.) produce ion pairs in the silicon that are collected by the strips and detected by a custom ASIC that contains 1000 charge sensitive amplifiers and the digital logic needed to read out the data. This ASIC chip is located inside the detector, next to the silicon strips. The signals are very small, and can be corrupted by electromagnetic interference.
We have designed DCDC converters with spiral air core (no iron or ferrite) inductors embedded in multilayer PCBs to power these chips for the next generation of detectors. To test these DCDC converters we use a Silicon strip detector that has a 410 μm thick silicon substrate with 56 μm wide strips. We have found that the EMI from the converter in this case is predominately from electrostatic coupling to the silicon strips. The strips are terminated in a charge sensitive amplifier at the readout end while the other end is floating. We have found that this is easily shielded from the spiral coils by a thin 50 μm Al foil.
We will report on buck converters with air core coils using commercial chips operating at 1 MHz and 6 Amps and at 20 MHz and 0.8 Amps.
Our radiation tests on commercial converter chips with Gammas, protons and neutrons show that a thin gate oxide is a necessary condition (but not sufficient) for high radiation tolerance (reported in 1984).

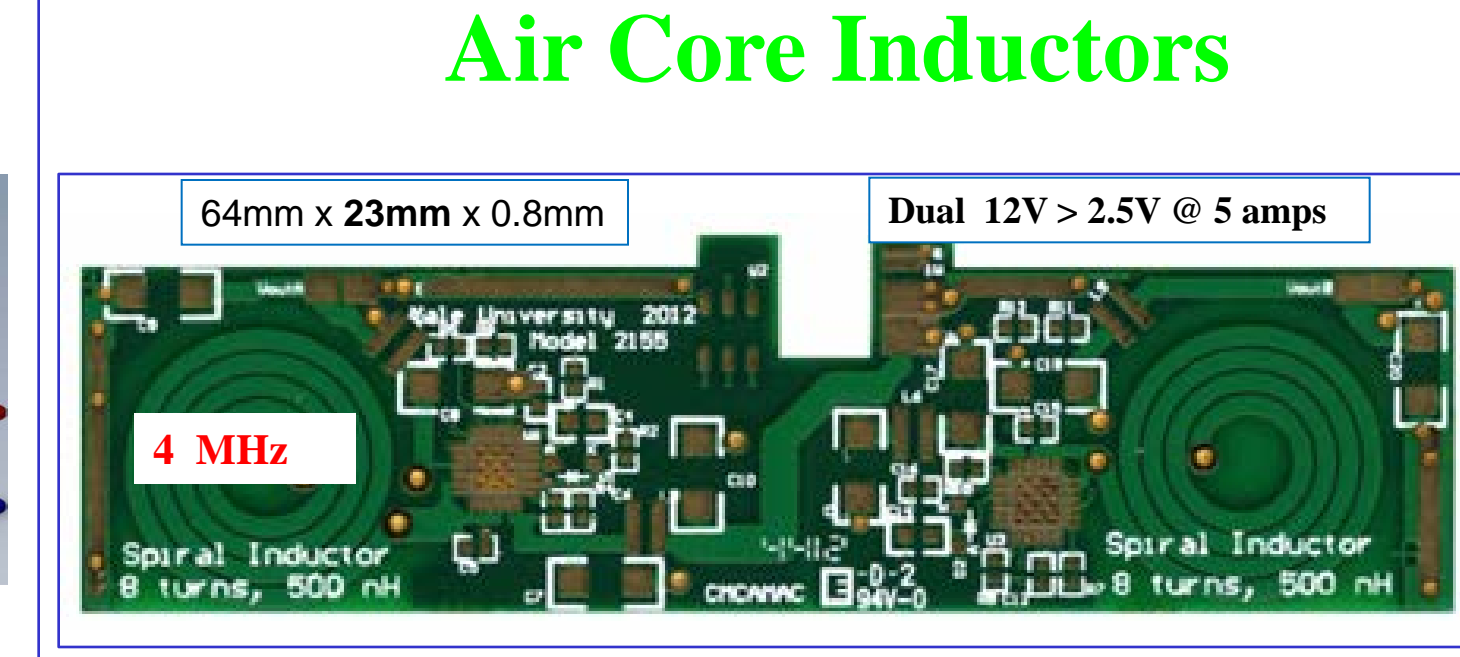
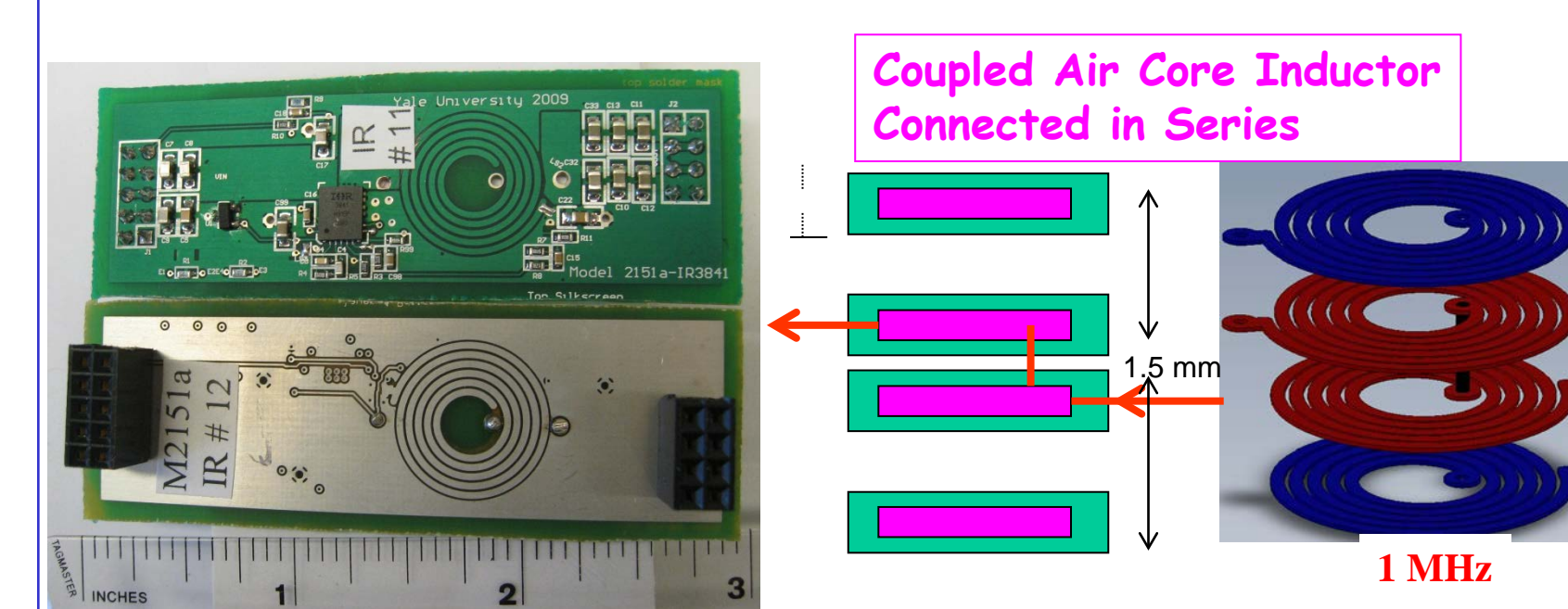

Air Core Inductors

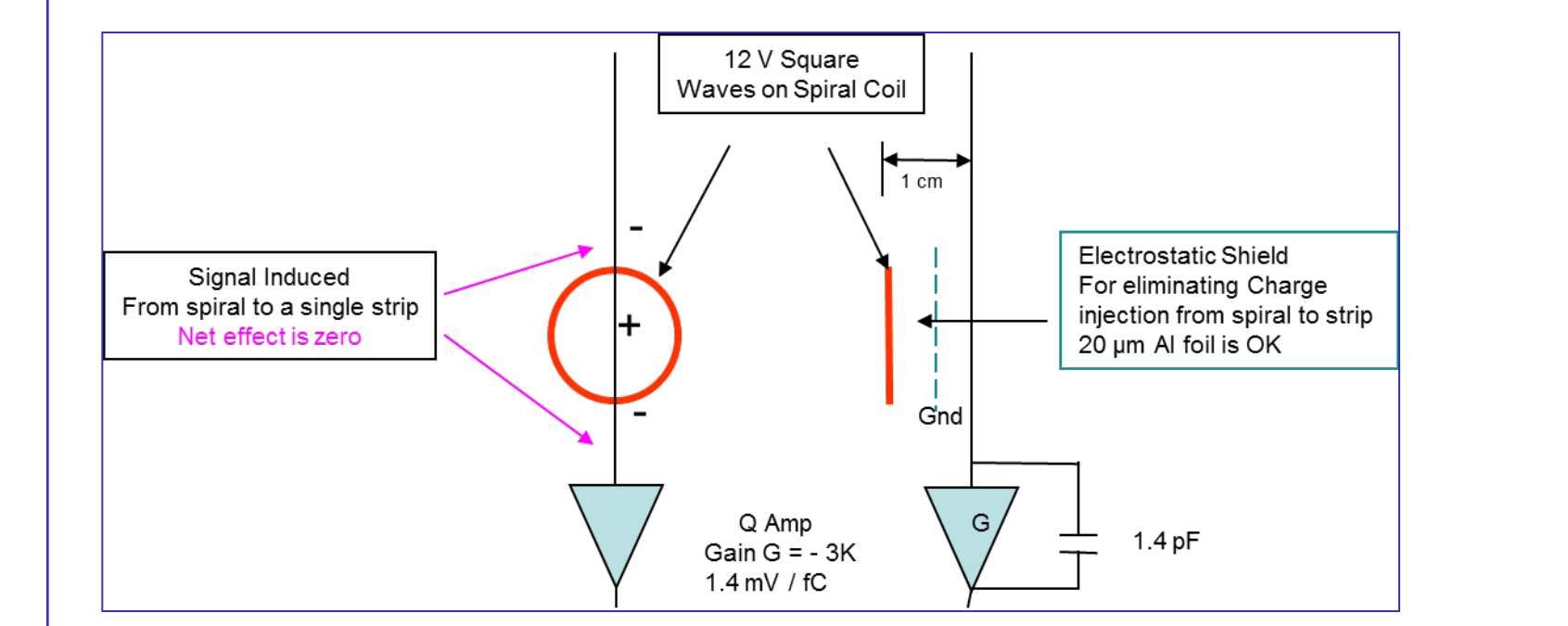
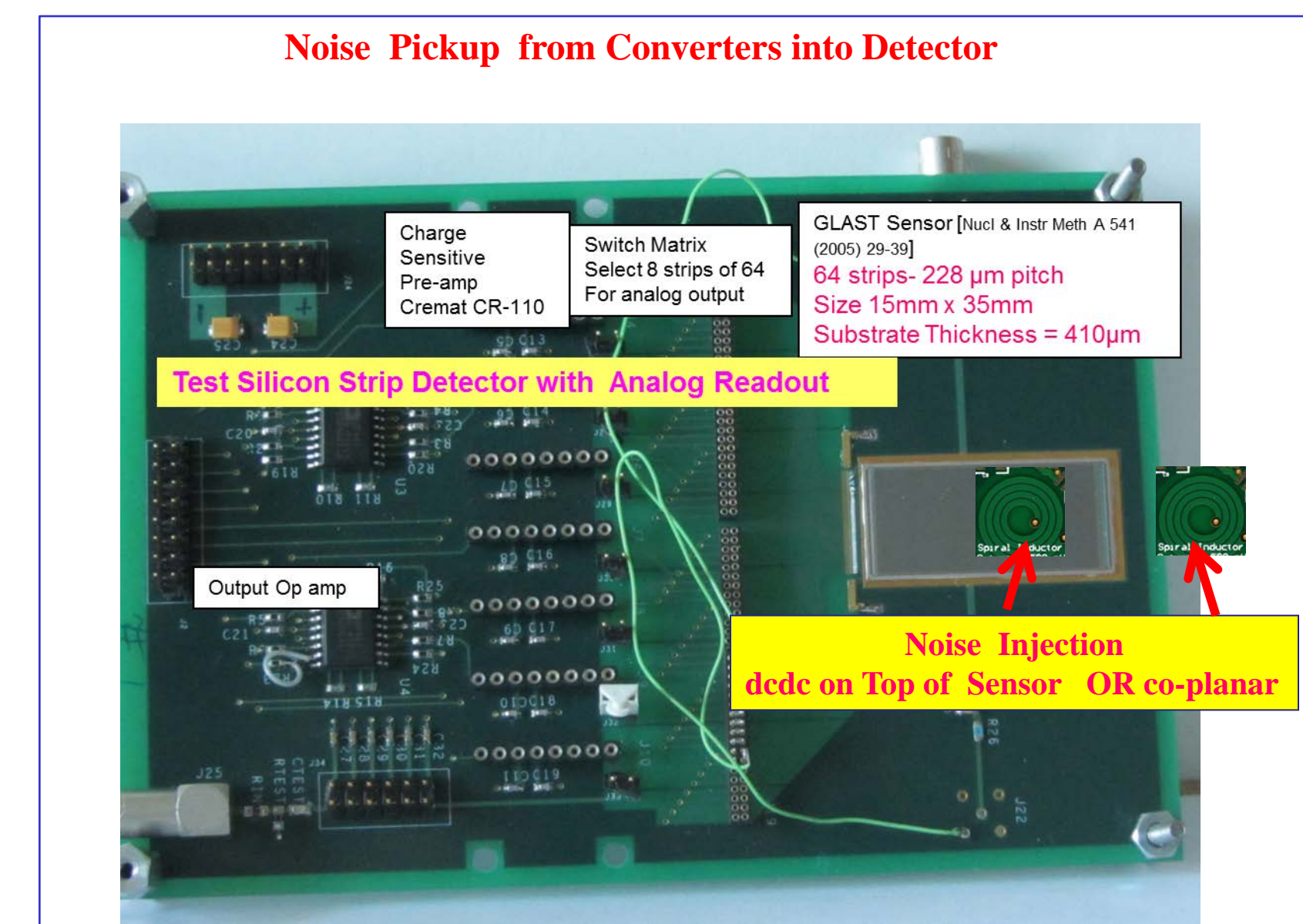
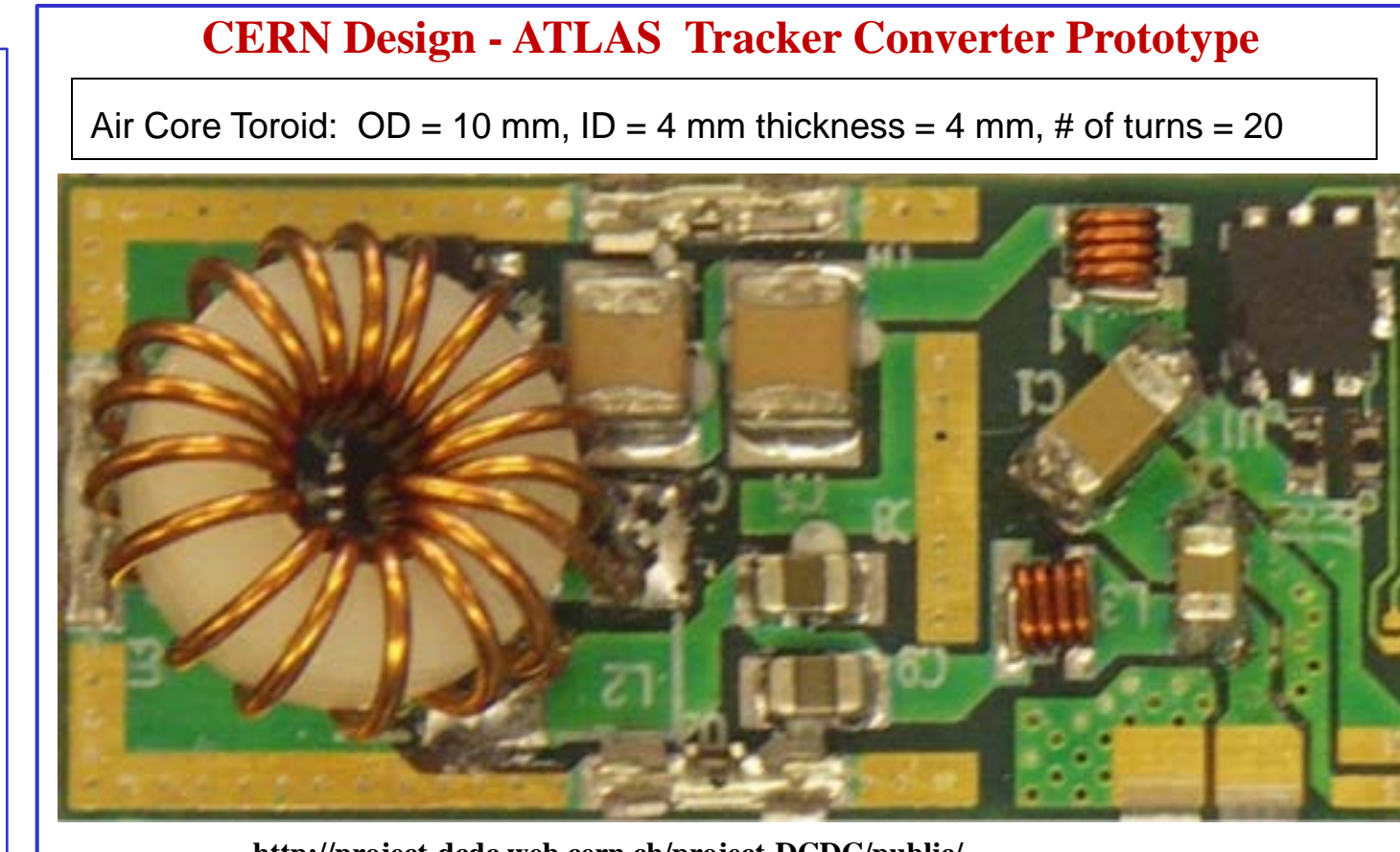

Why do we need electrostatic Shield ?
Parallel Plate Capacitance in pF = 0.225 x A x K / Distance

Area = Inches	Distance = Inches	C in femto farads
1	0.4	500
GLAST = .5 x 1.3	0.6	
per strip = 0.6 / 48	0.0125	6.25

1 volt swing on spiral coil will inject Q = 6 femto Coulombs
Charge from one minimum ionizing particle (1 mip) = 7 femto Coulombs

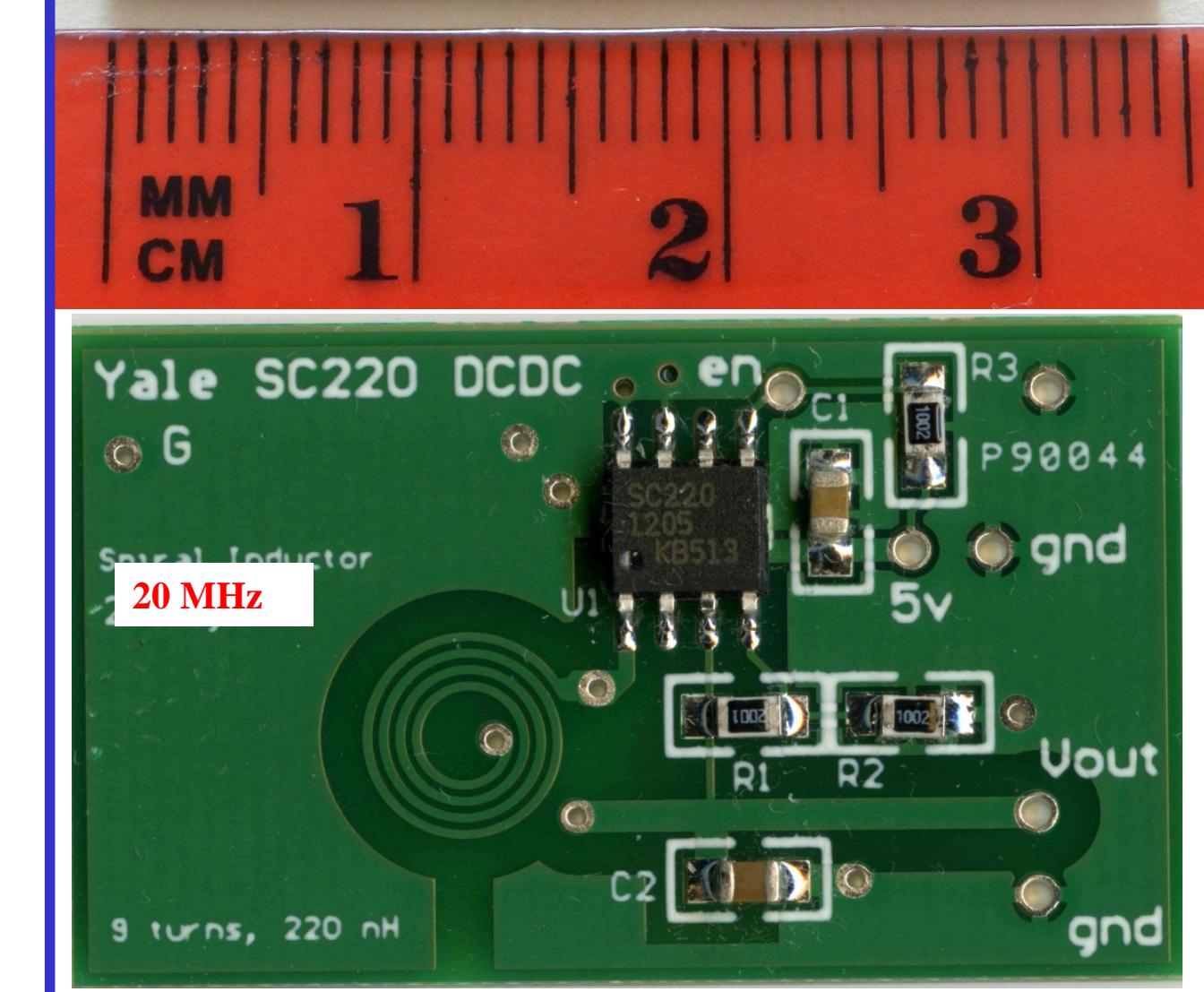
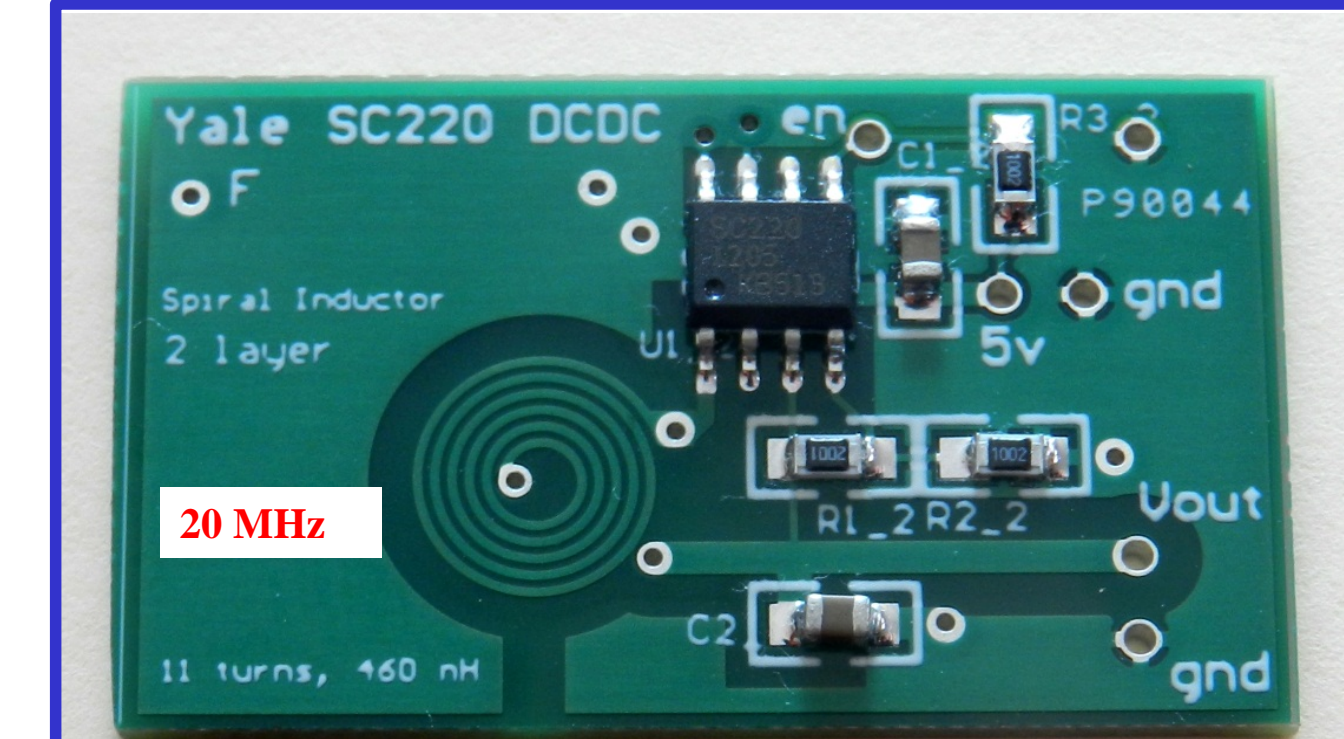

Inductance Panel to test EMI Coils phase / anti-phase Multi-Layer Coils

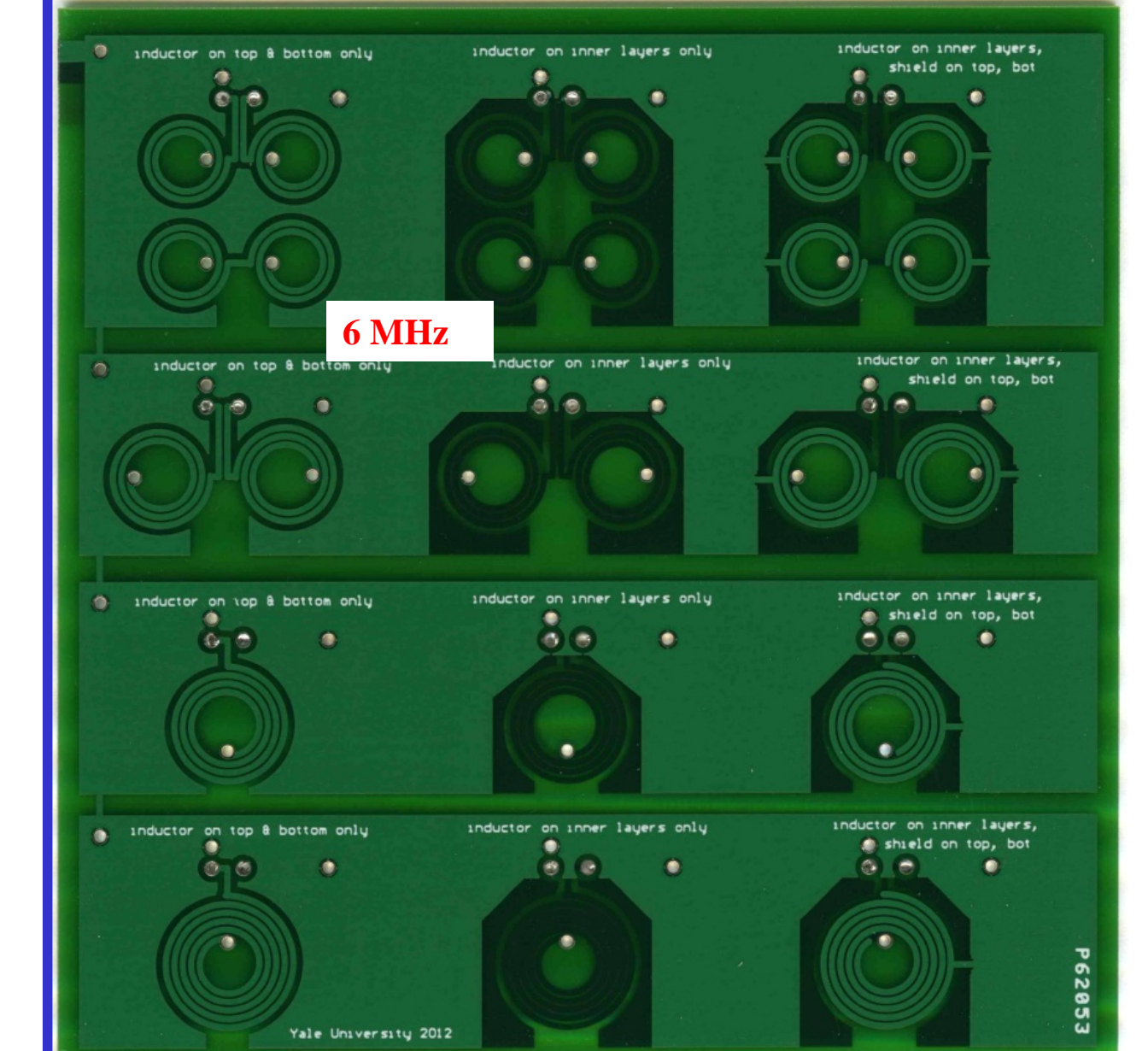

Various views of a proton-proton collision creating many new particles

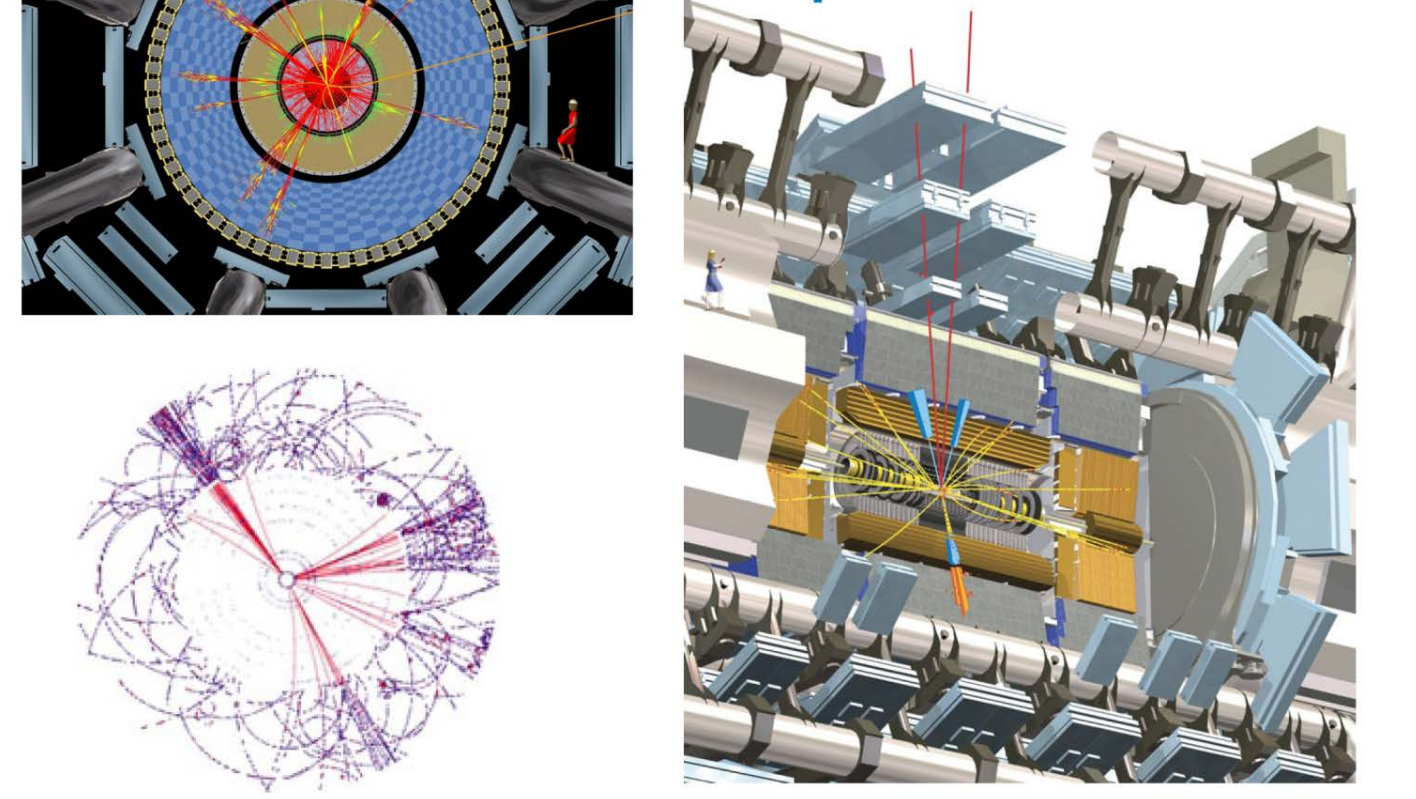

Atlas Detector is underground

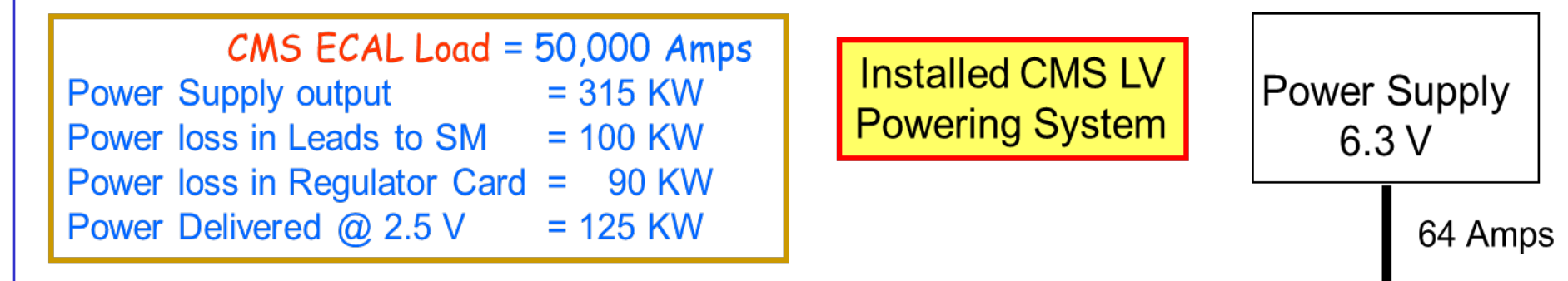
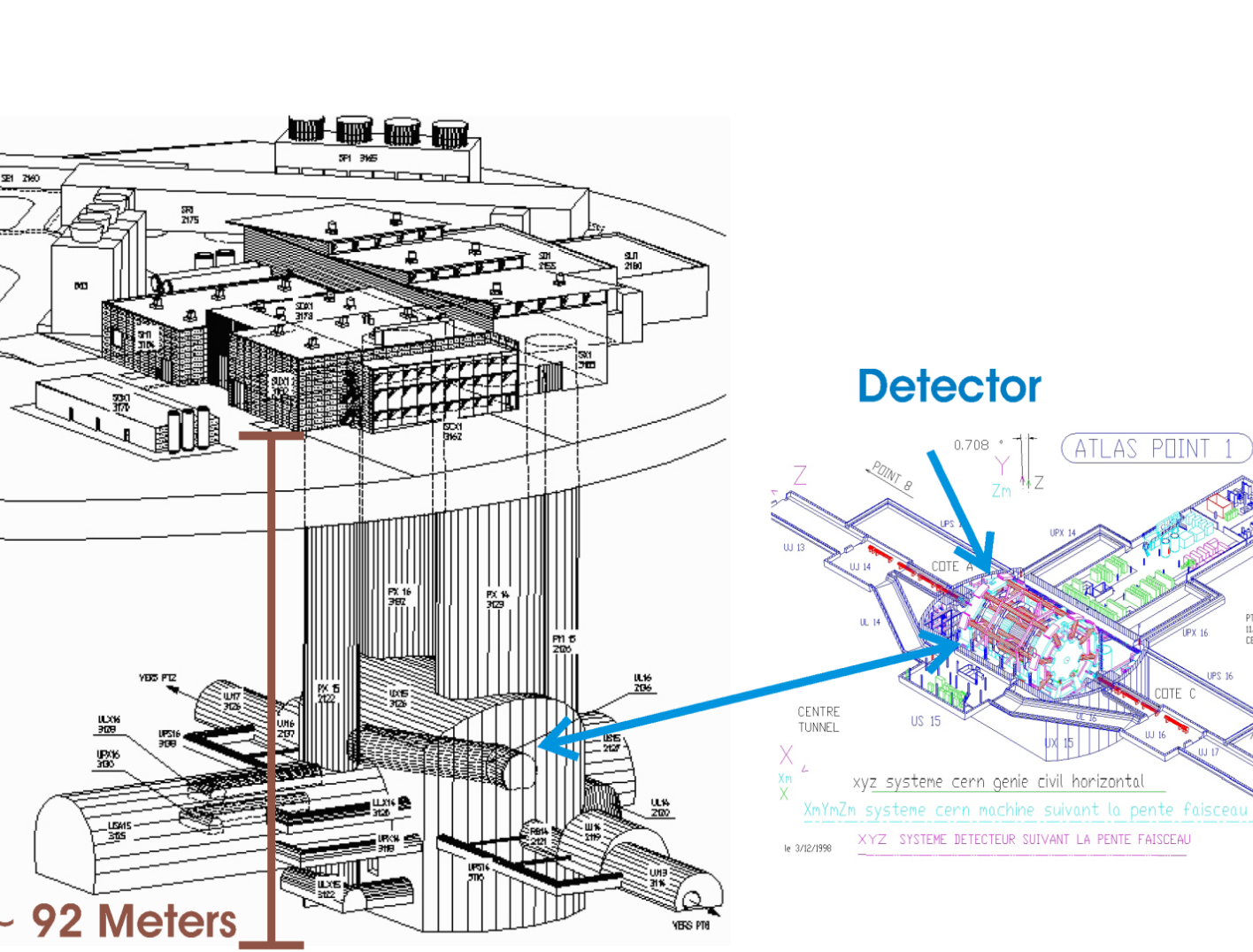

of Power Supplies ~ 700
of ST LDO Chips = 35 K LHC Radiation Hard made by ST Microelectronics
of LVR Cards = 3.1 K
Yale: Designed, built, burn-in and Tested.

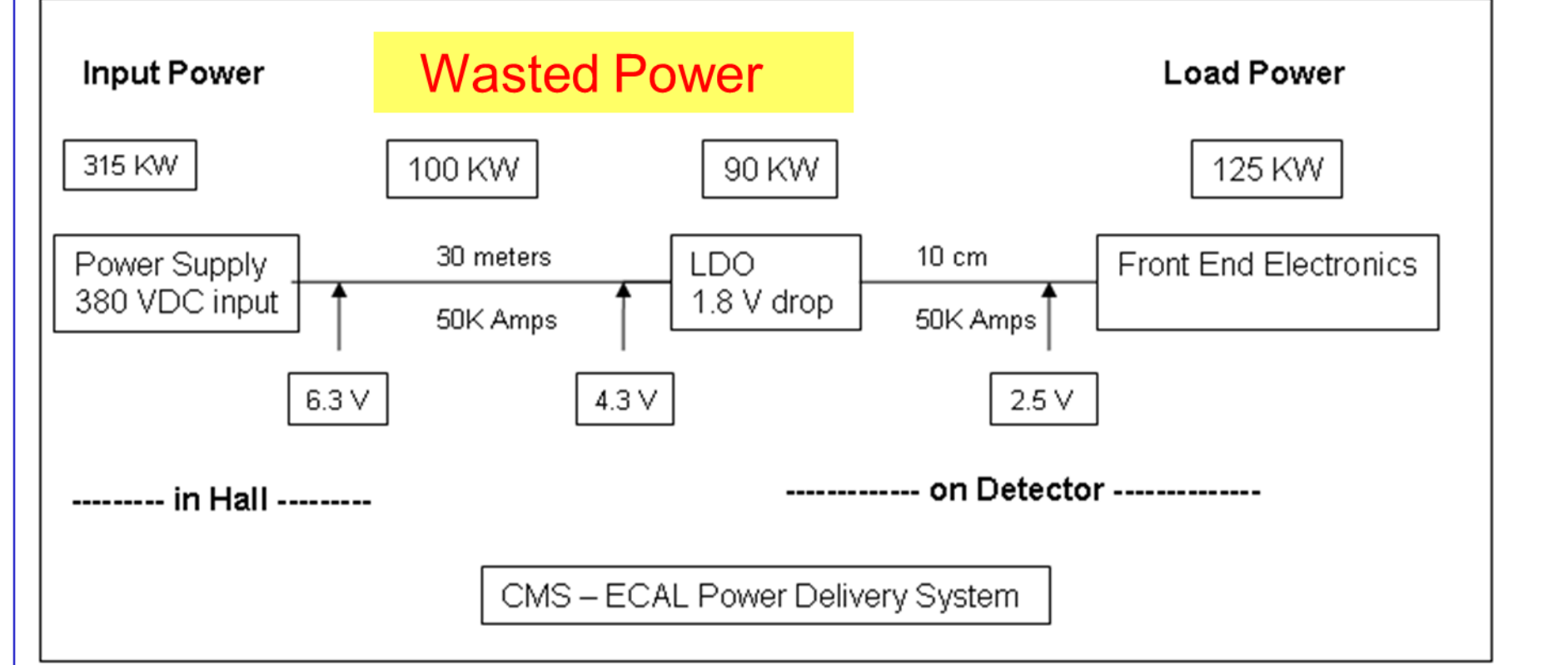
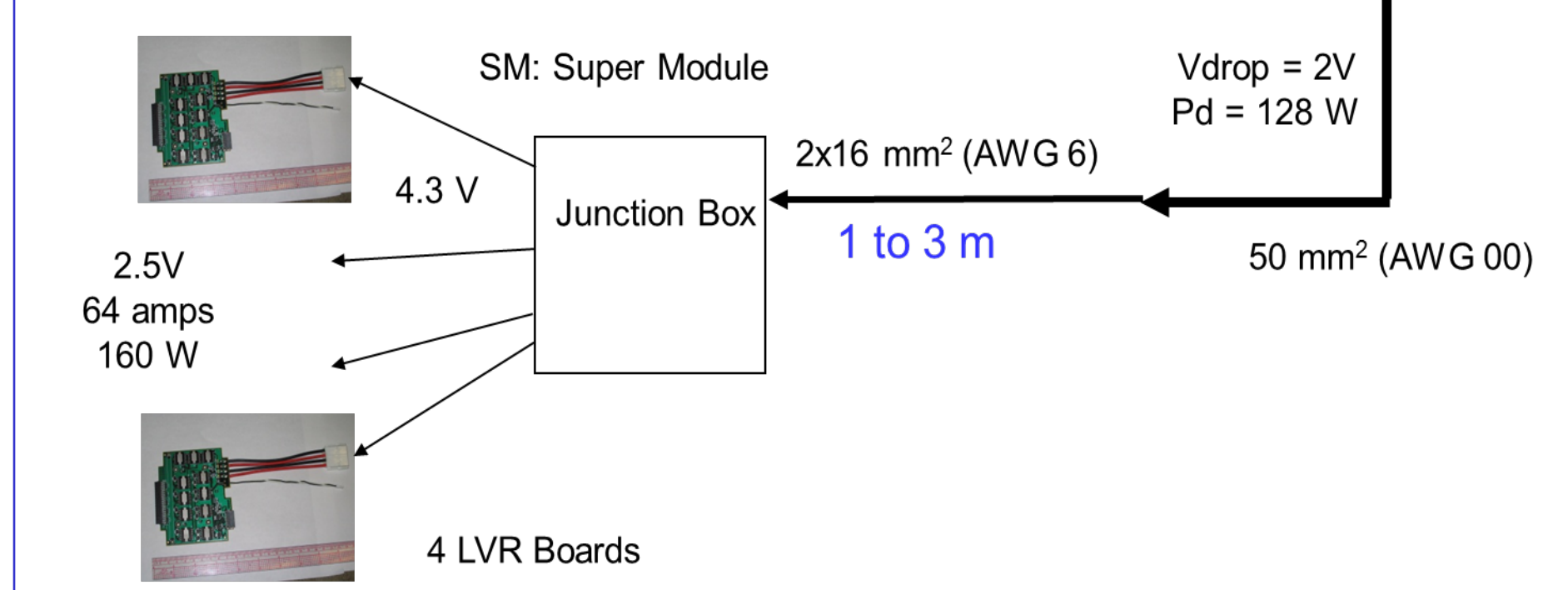

Power delivery Efficiency = 30 %
Including Heat Removal Efficiency = 20 %
It takes 2 watts of power to remove 1 watt of heat load

