

How to Deliver Oodles and Oodles of Current to HEP Detectors in High Radiation and Magnetic Fields?

Satish K Dhawan
Yale University



SLAC: Advanced Instrumentation Seminar
February 18, 2010

1 Oodle = 10,000 amps

Agenda

- ❖ How we got into this Power Supply mess
- ❖ Type of Converters
- ❖ Coil Development
- ❖ Proximity Effect
- ❖ Plug in cards
- ❖ Noise Test with Detectors
- ❖ Magnetic Field
- ❖ Radiation Effect > Thin Oxide
- ❖ Radiation Test Results
- ❖ GaN Wide band Gap materials
- ❖ Industry Developments
- ❖ Did we find a commercial part for sLHC ?
- ❖ Market Trends Single Chip
- ❖ Conclusions

Collaborators:

Yale University: Keith Baker

Brookhaven National Laboratory: Hucheng Chen, James Kierstead, Francesco Lanni, David Lynn, Sergio Rescia,

CMS ECAL: 5 Oodles (50 Kamps) .

Power Supply output = 315 KW
Power loss in Leads to SM = 100 KW
Power loss in Regulator Card = 90 KW
Power Delivered @ 2.5 V = 125 KW

of Power Supplies ~ 700

of ST LDO Chips = 35 K LHC Radiation Hard made by ST Microelectronics

of LVR Cards = 3.1 K.

Yale: Designed, built, burn-in and Tested.

Power Supply
6.3 V

64 Amps

30 m

Vdrop = 2V
Pd = 128 W

2x16 mm² (AWG 6)

1 to 3 m

50 mm² (AWG 00)

SM: Super Module

4.3 V

Junction Box

2.5V

64 amps

160 W

4 LVR Boards

**Power Delivery Efficiency = 40%
NOT INCLUDED**

1. Power Supply efficiency
2. Water cooling
3. Removal of Waste heat
4. Air Conditioning

What can we do?

- Is there a better way to distribute power ?
- High Radiation
- Magnetic Field 4 T
- Load ~1 V Oodles of current
- Feed High Voltage and Convert - *like AC power transmission*
- Commercial Technologies — *No Custom ASIC Chips*
- Learn from Semiconductor Industry
- Use Company Evaluation Boards for testing

IEEE JOURNAL OF SOLID-STATE CIRCUITS, VOL. 40, NO. 4, APRIL 2005

A 233-MHz 80%–87% Efficient Four-Phase DC–DC Converter Utilizing Air-Core Inductors on Package

Peter Hazucha, *Member, IEEE*, Gerhard Schrom, Jaehong Hahn, Bradley A. Bloechel, *Associate Member, IEEE*, Paul Hack, Gregory E. Dermer, *Member, IEEE*, Siva Narendra, *Member, IEEE*, Donald Gardner, *Member, IEEE*, Tanay Karnik, *Senior Member, IEEE*, Vivek De, *Member, IEEE*, and Shekhar Borkar, *Member, IEEE*

Circuit Research, Intel Laboratories, Intel Corporation, Hillsboro, OR 97124

Flat Inductors on the Chip.

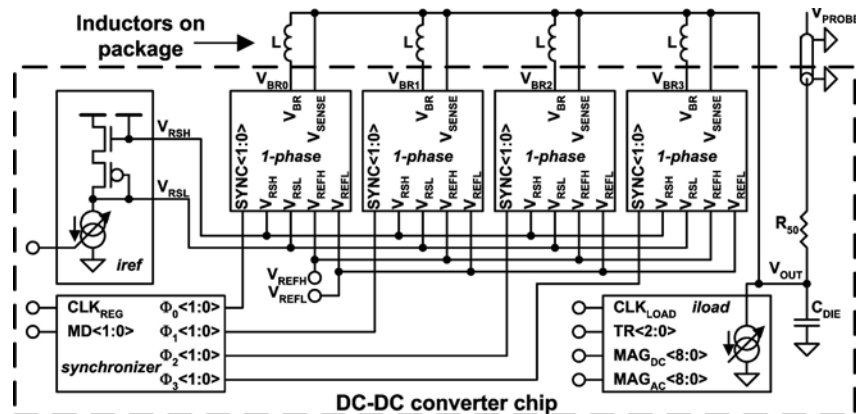

Block diagram of a high-frequency four-phase interleaved dc–dc converter.

Buck Regulator Efficiency after 100 Mrad dosage

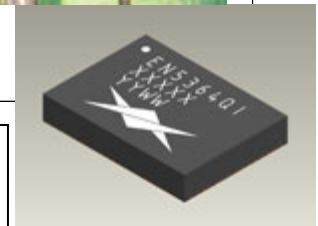
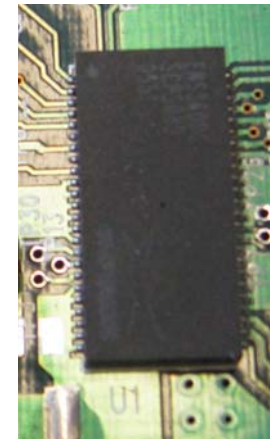
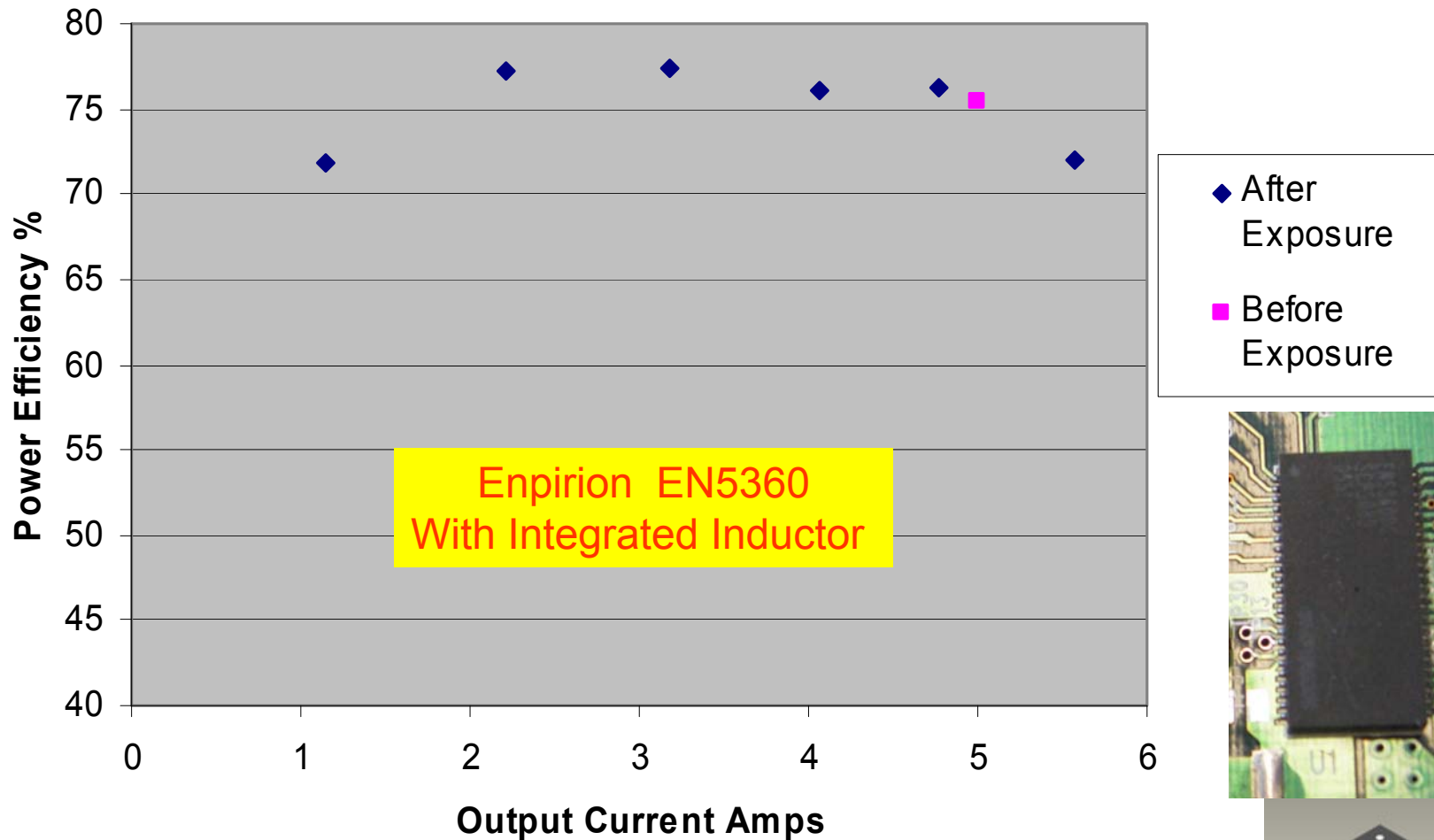

Found out at Power Technology conference 0.25 μm Lithography

- Irradiated Stopped on St. Valentines Day 2007
- We reported @ TWEPP 2008 - IHP was foundry for EN5360

Length of Power Cables = 140 Meters

LHC Solution



sLHC Solution

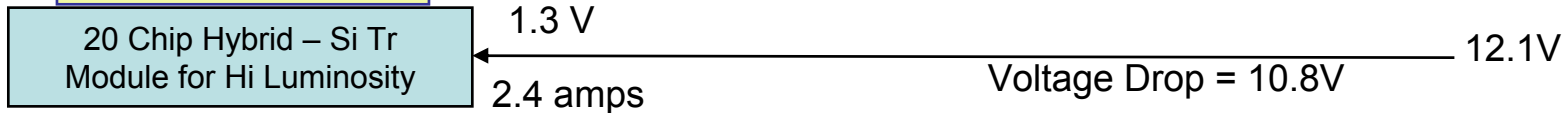

2 Step Solution

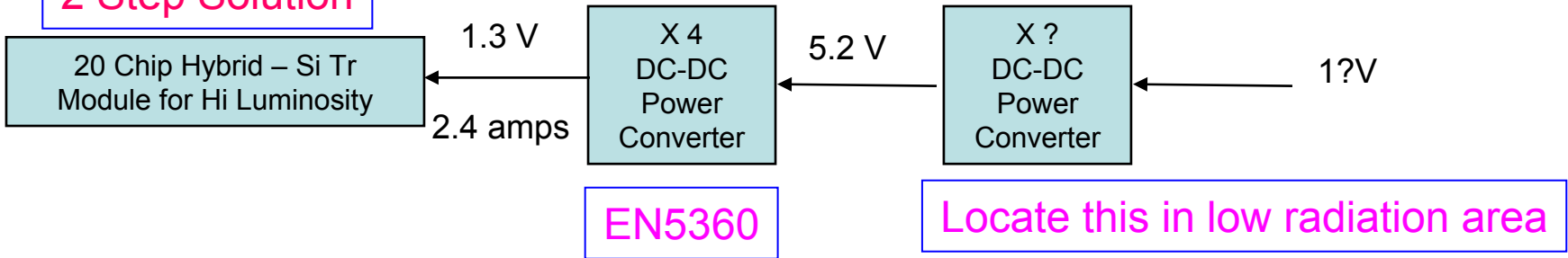

1 Step Solution Desired

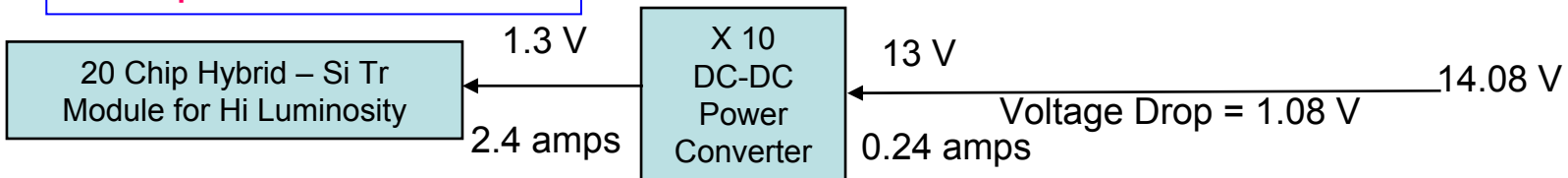

Power Delivery with Existing SCT Cables (total = 4088)

Resistance = 4.5 Ohms

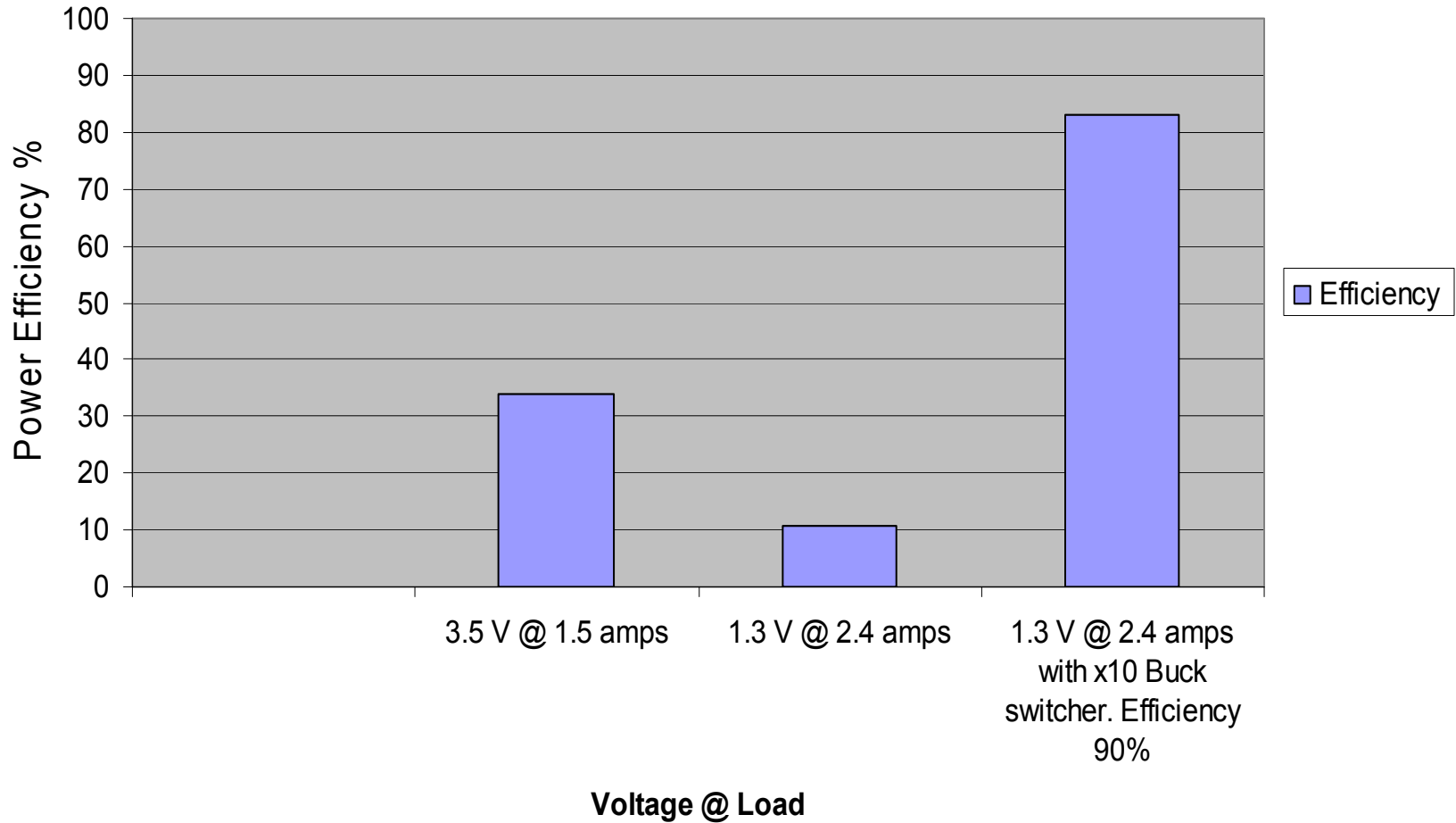

Type of High to Low Voltage Converters without transformers

❖ Charge pumps

- Normally limited to integral fractions of input voltage
- Losses proportional to switch losses
- Can provide negative voltage

❖ Buck Converter – Used in consumer & Industrial Electronics

- Needs an ASIC, Inductor and Capacitors
- Cannot provide a negative voltage
- Topology allows for more flexibility in output voltage than charge pump
- Much more common use in commercial applications

Charge Pump

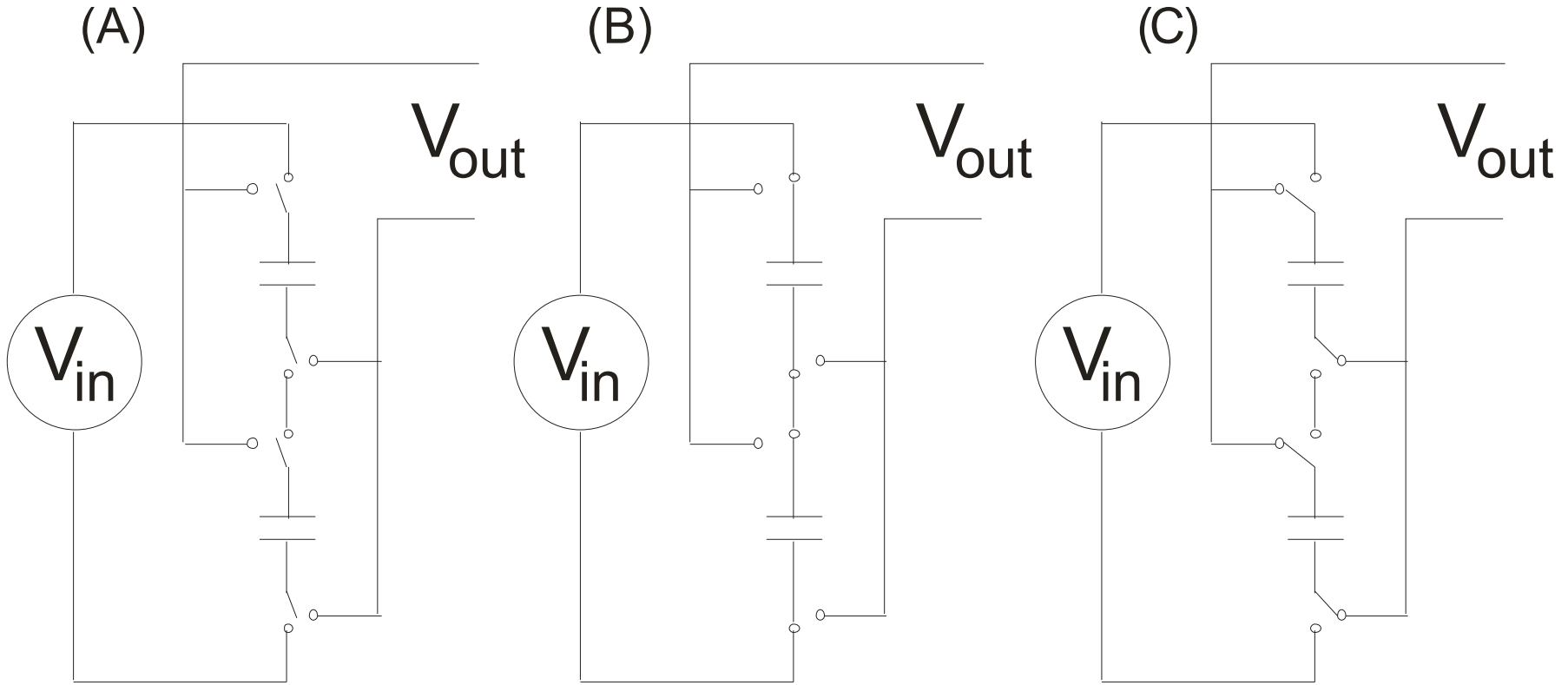

(A) 2-1 ratio charge pump.

(B) Charging.

(C) Discharging

Use for low currents / Polarity reversal

Synchronous Buck Converter

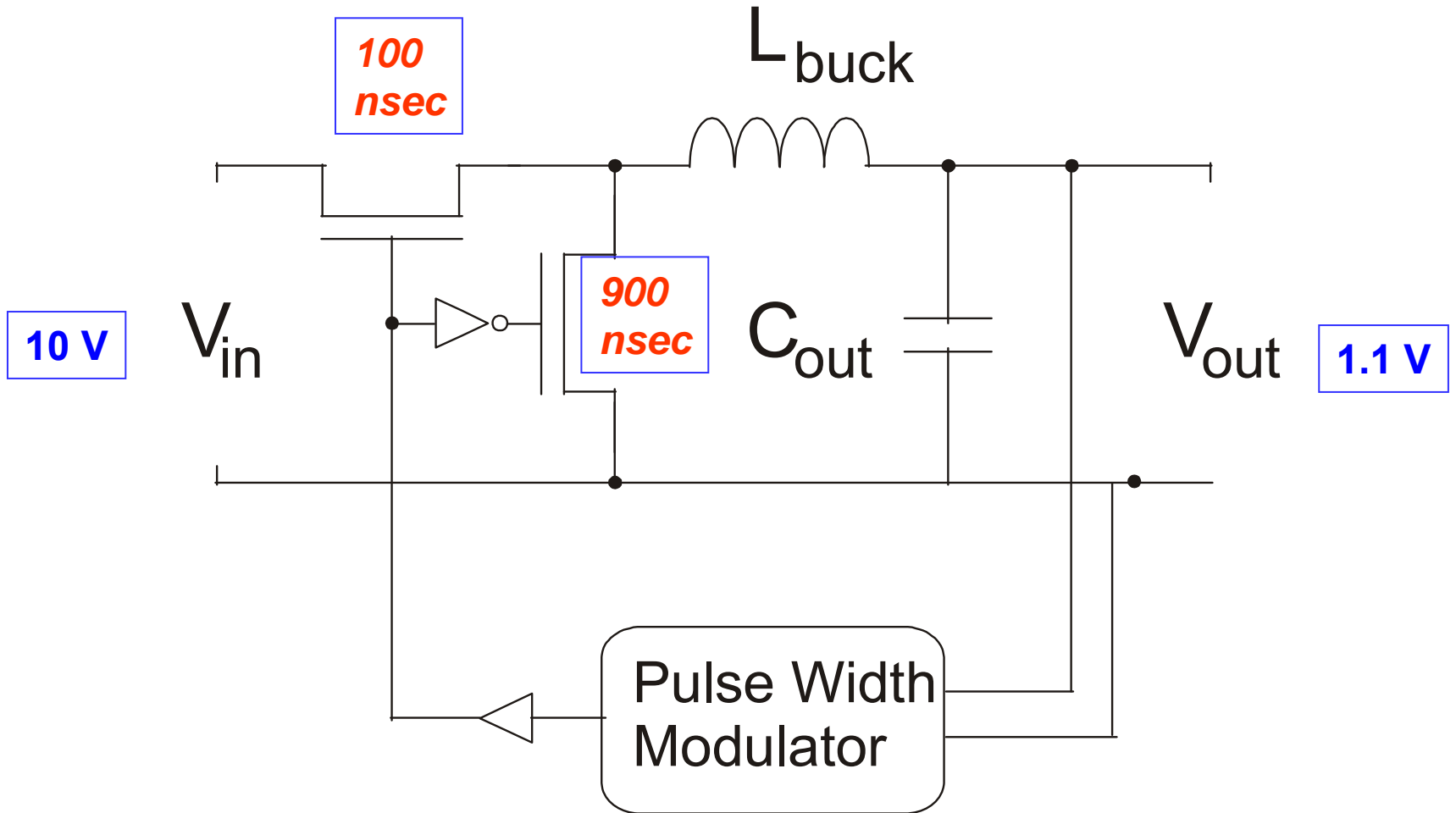

Frequency = 1 MHz

Synchronous Buck Converter

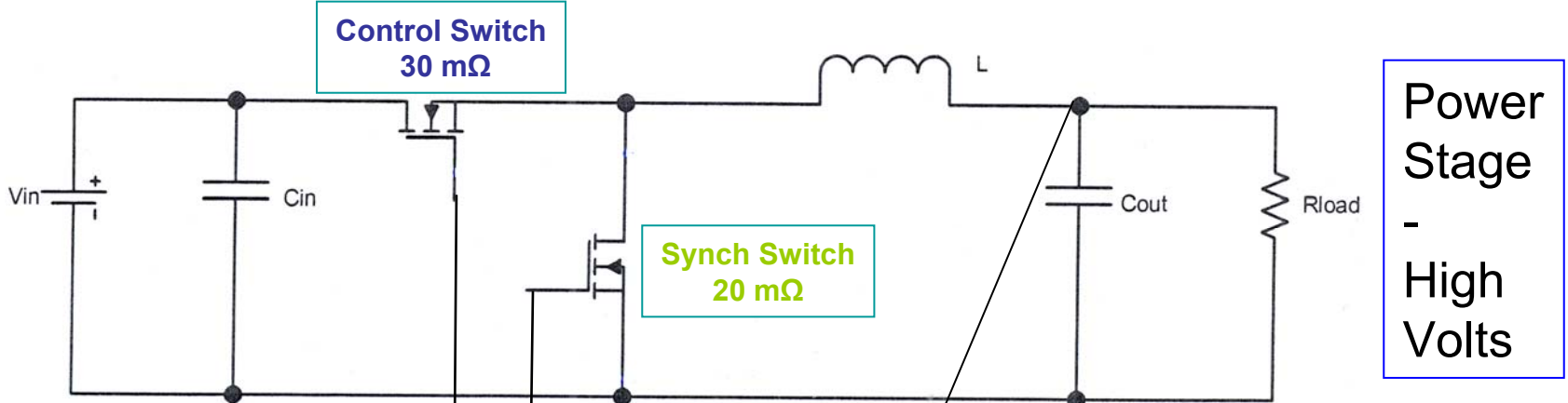

Controller
Low Voltage

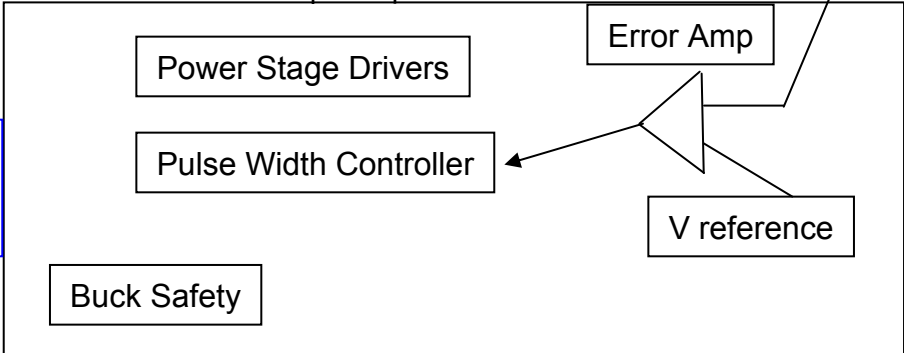

Minimum Switch ON Time
Limits Max Frequency
10 nsec @ 10 MHz

Vout = 11%

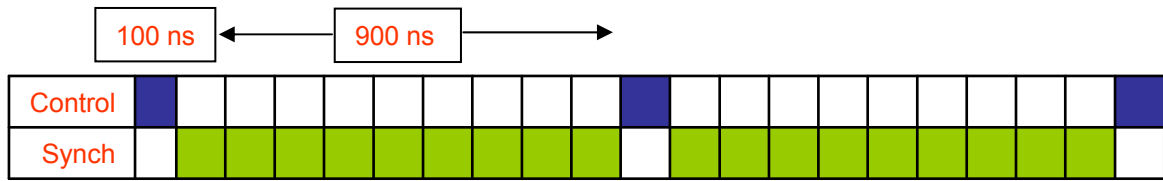

Control Switch: Switching Loss > I²
Synch Switch: R_{ds} Loss Significant

Vout = 50%

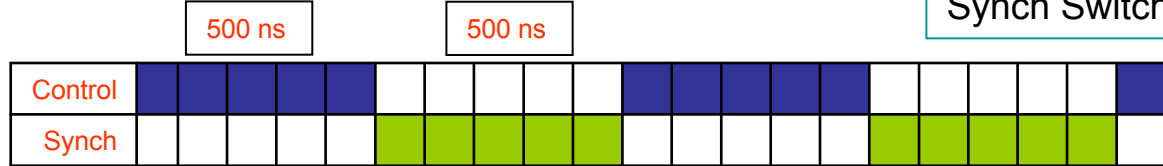

Coils under Study: Solenoid, Toroid, Spirals

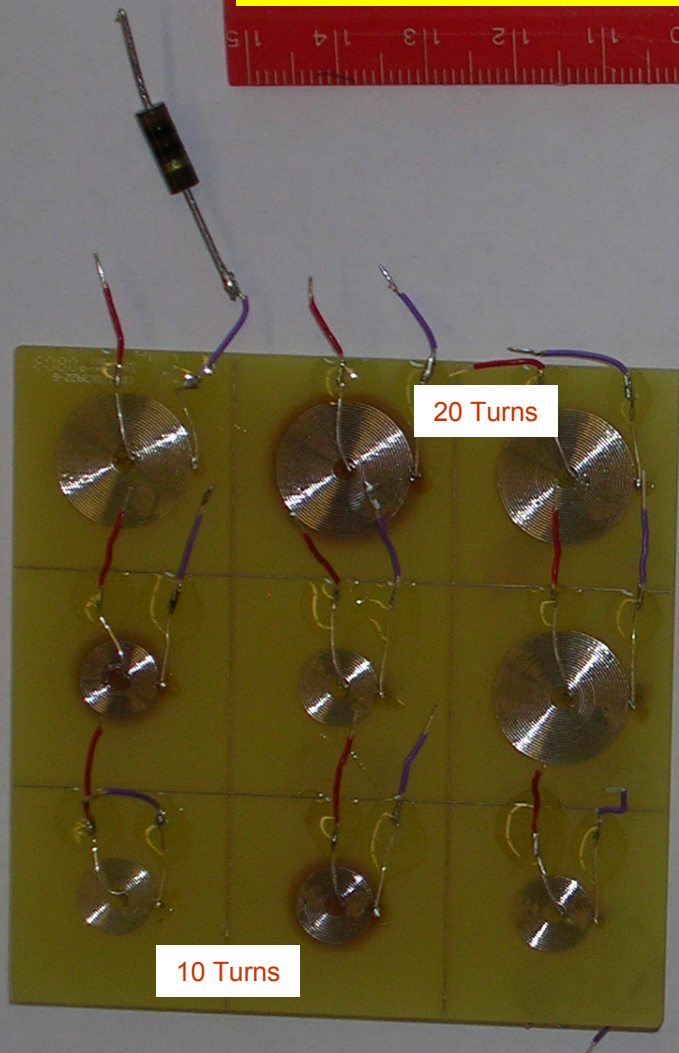

20 Turns

10 Turns

Spirals

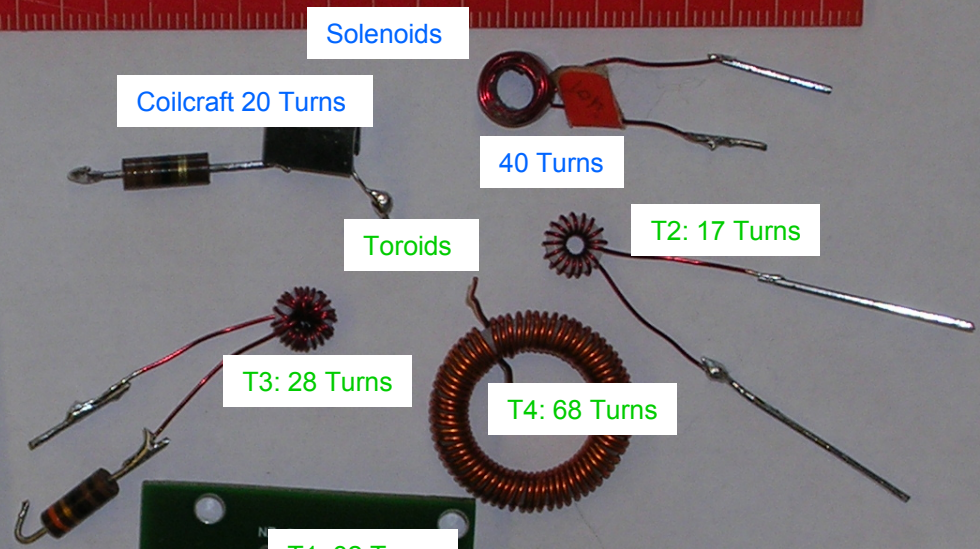

Solenoids

Coilcraft 20 Turns

40 Turns

Toroids

T2: 17 Turns

T3: 28 Turns

T4: 68 Turns

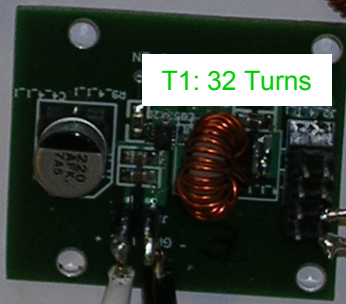

T1: 32 Turns



Renco 1 μ H

Proximity Effect

2 oz copper for coils

2 coils in series for larger L

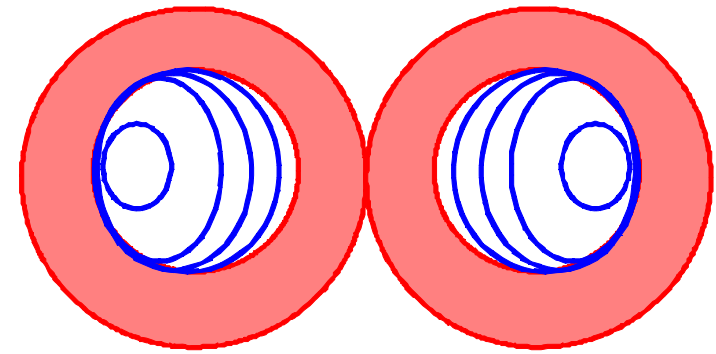

Inductance and Resistance vs Coil Spacing

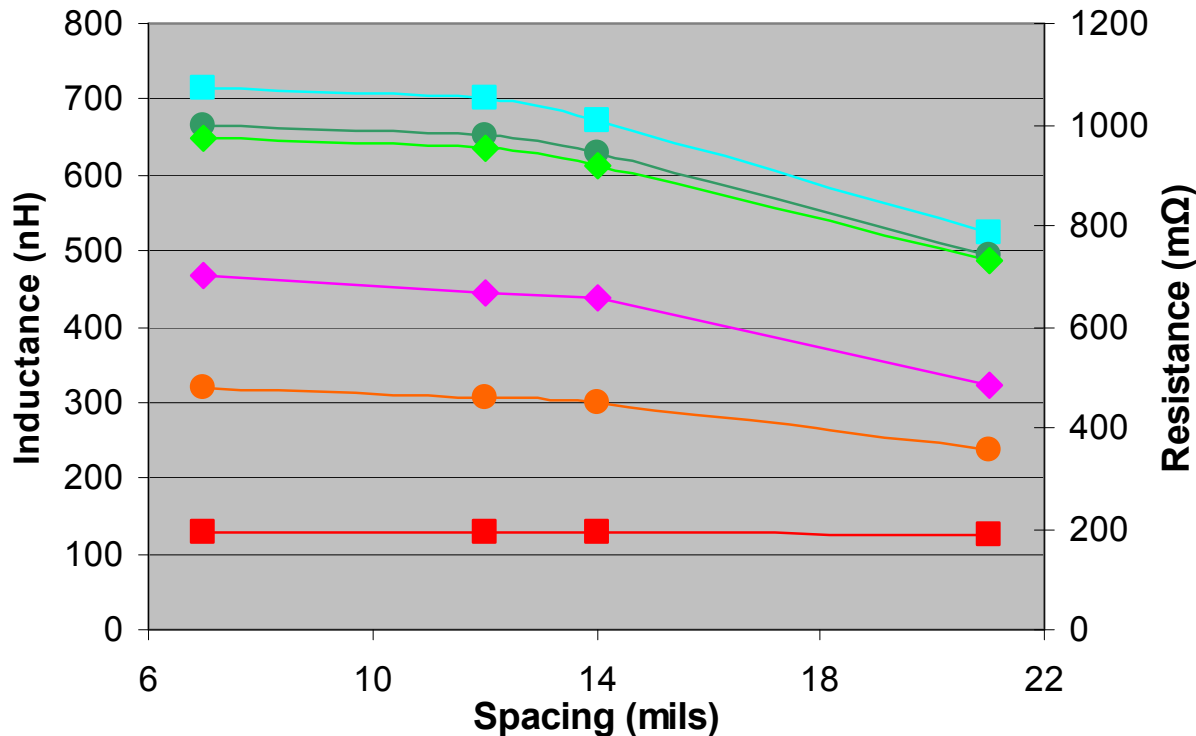

Current Distribution in Neighboring Conductors

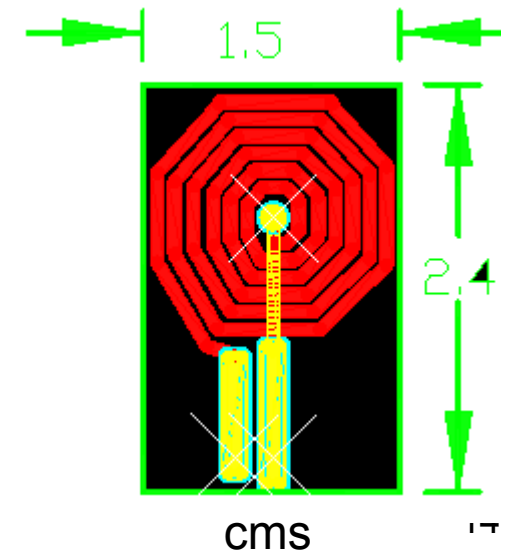

A proximity effect is seen in the spiral coils

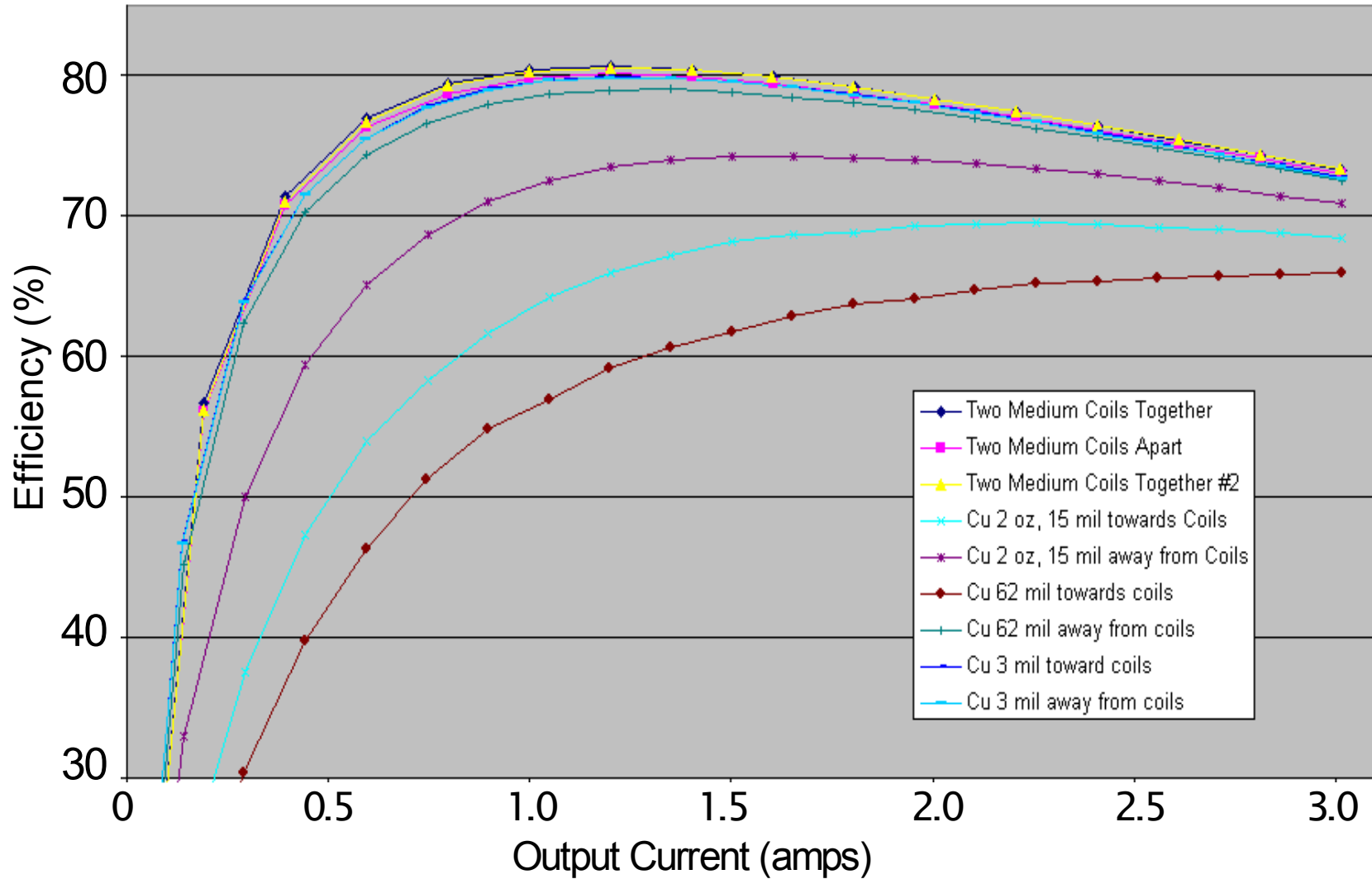

2 spiral Coils in series- Squeezing together lowers efficiency!

Plug In Card with Shielded Buck Inductor

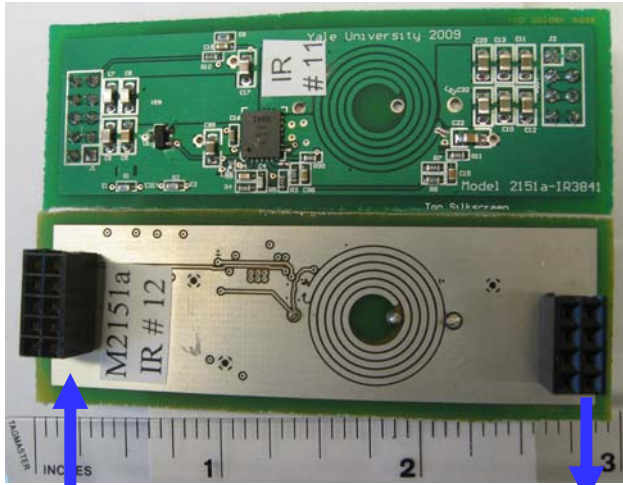

12 V

2.5 V
@ 6 amps

Coupled Air Core Inductor
Connected in Series

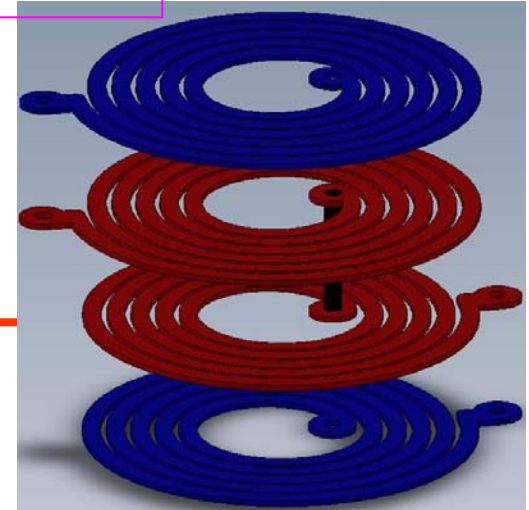
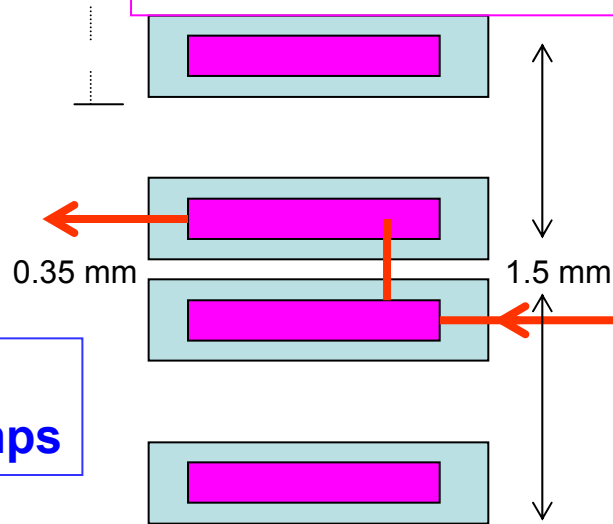

Spiral Coils Resistance in mΩ

	Top	Bottom
3 Oz PCB	57	46
0.25 mm Cu Foil	19.4	17

Different Versions

❖ Converter Chips

Max8654 monolithic
IR8341 3 die MCM

❖ Coils

Embedded 3oz cu
Solenoid 15 mΩ
Spiral Etched 0.25mm

**MAX8654 with embedded coils (#12), external coils (#17) or Renco Solenoid (#2)
Vout=2.5 V**

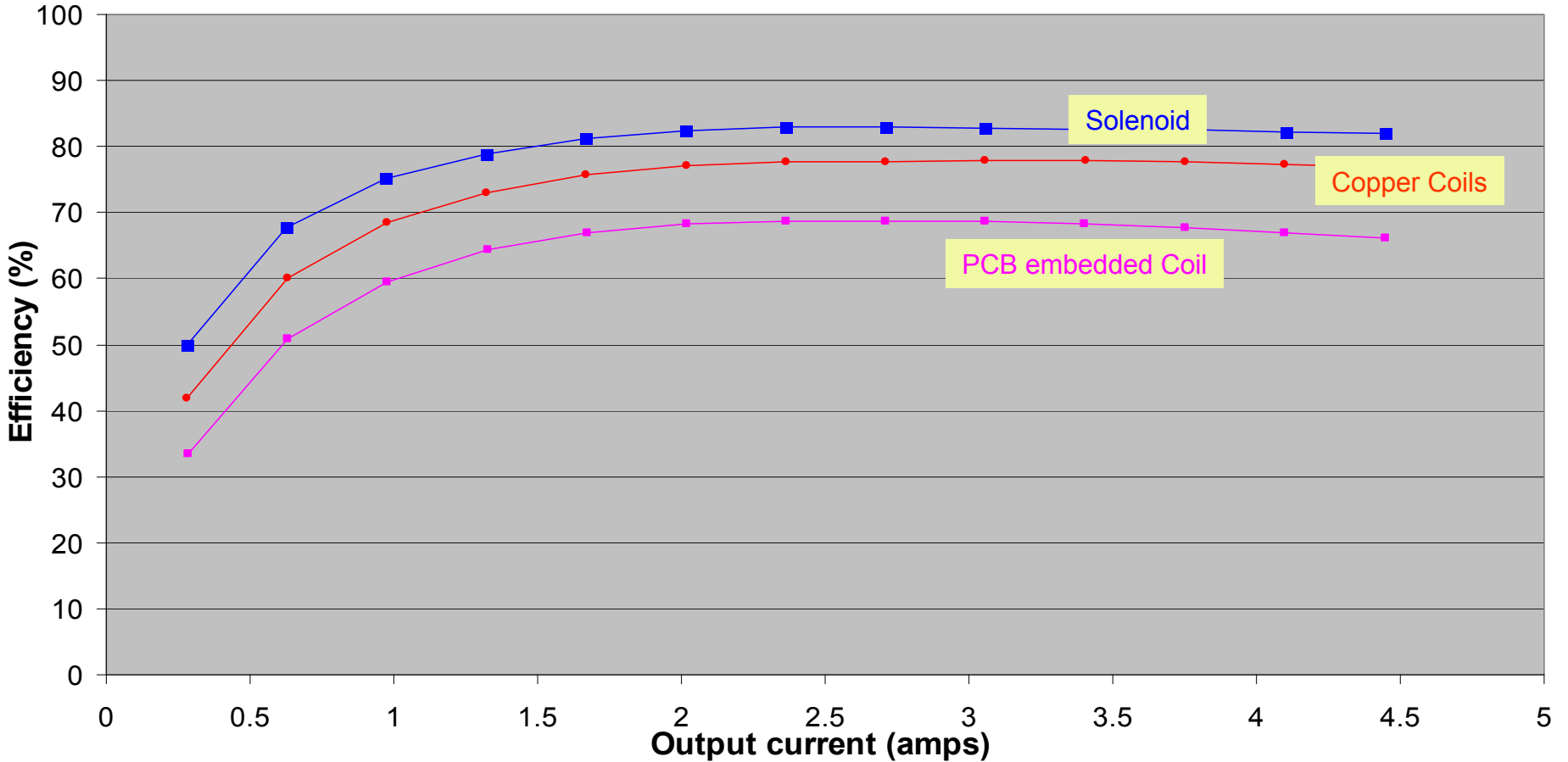

—■— MAX #12, Vin = 11.9 V —●— MAX #17, Vin = 11.8 V —■— MAX #2, Vin = 12.0 V

Test @ Yale

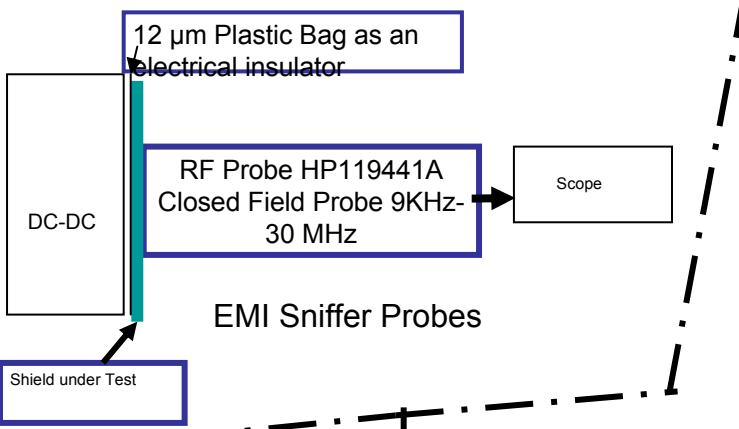

Noise Tests with Silicon Sensors

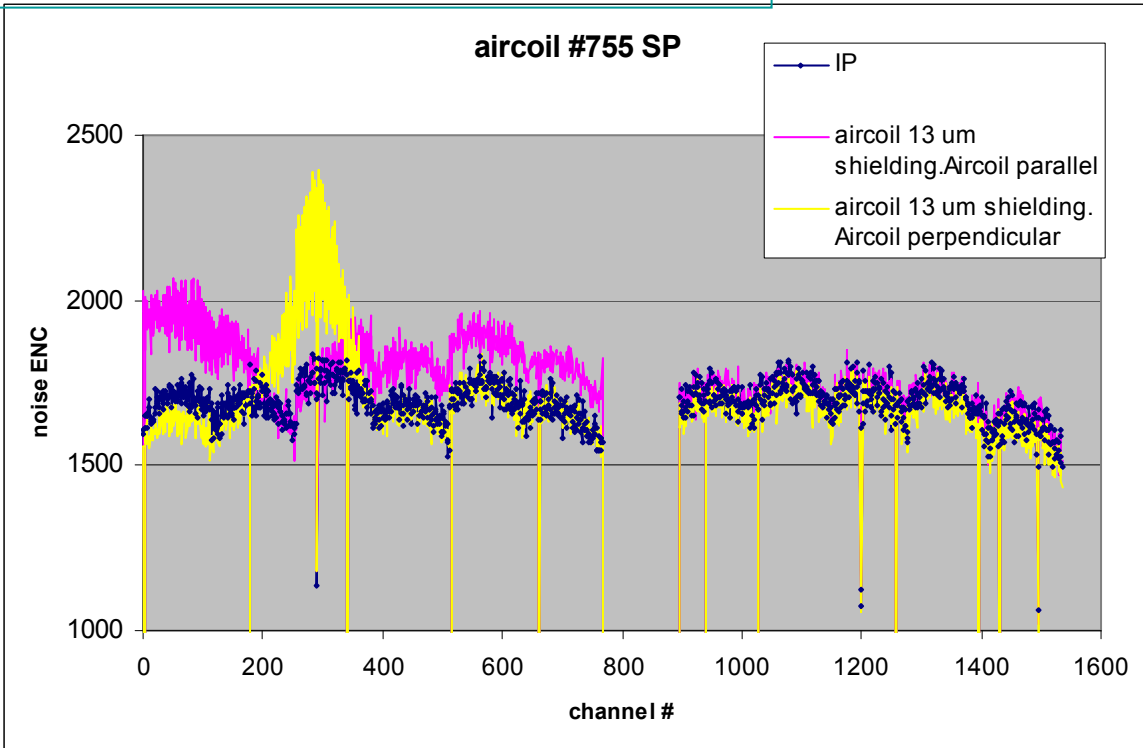

Air Core Solenoid

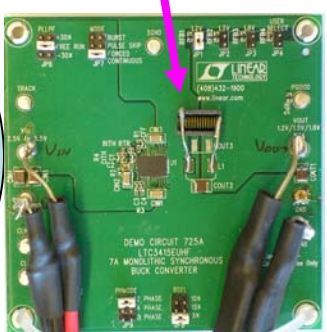

Test @ BNL

RHIC
Polarimeter
Silicon Sensor
With
Analog Readout
Noise on Scope

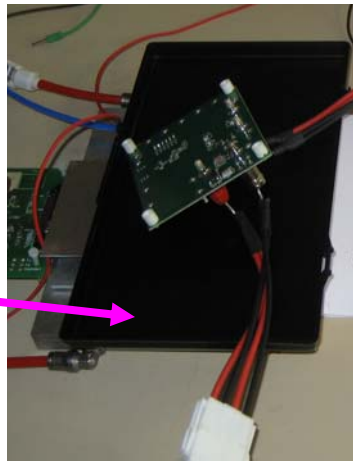

ATLAS Si Tracker
Module
12 ABCD Chips
2 Sensors
Protected by plastic

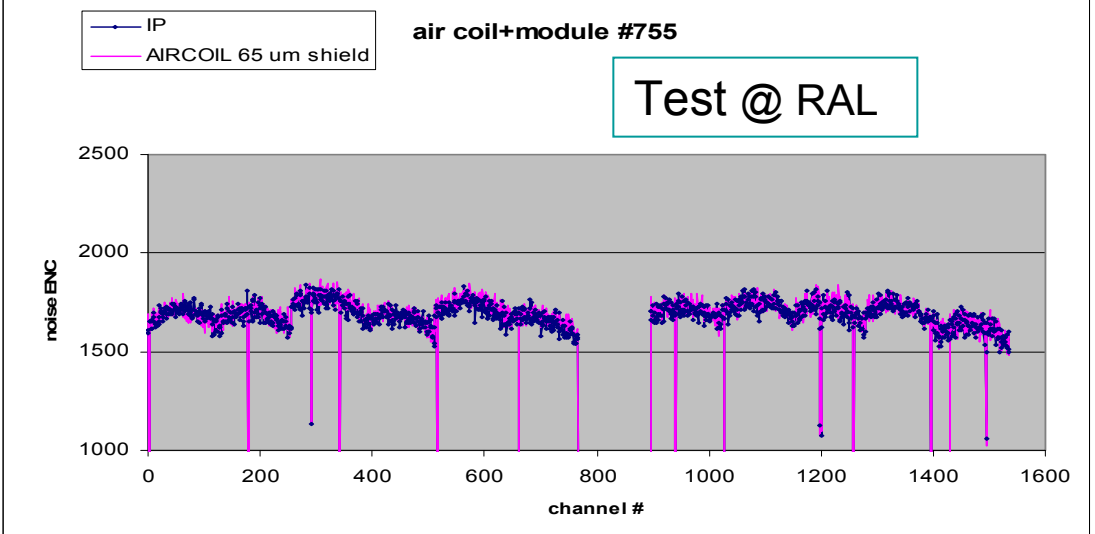

Test @ RAL

Test @ BNL

Only One Chip Bonded

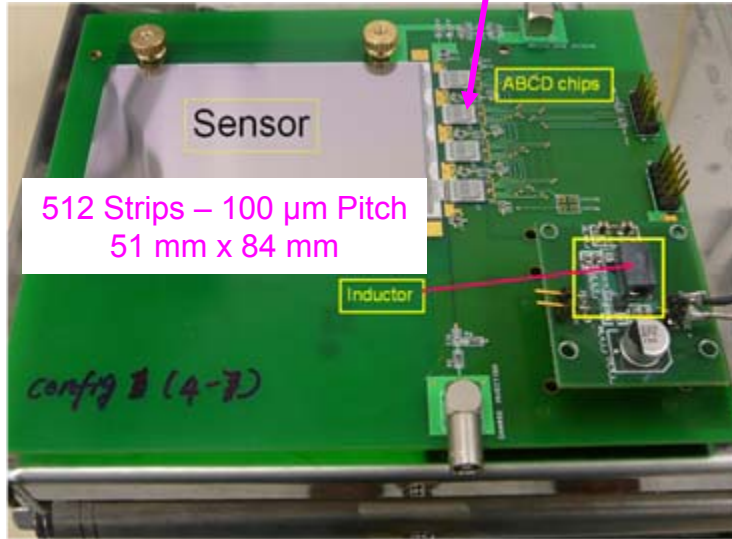

512 Strips – 100 μm Pitch
51 mm x 84 mm

Noise Tests with Silicon Sensors

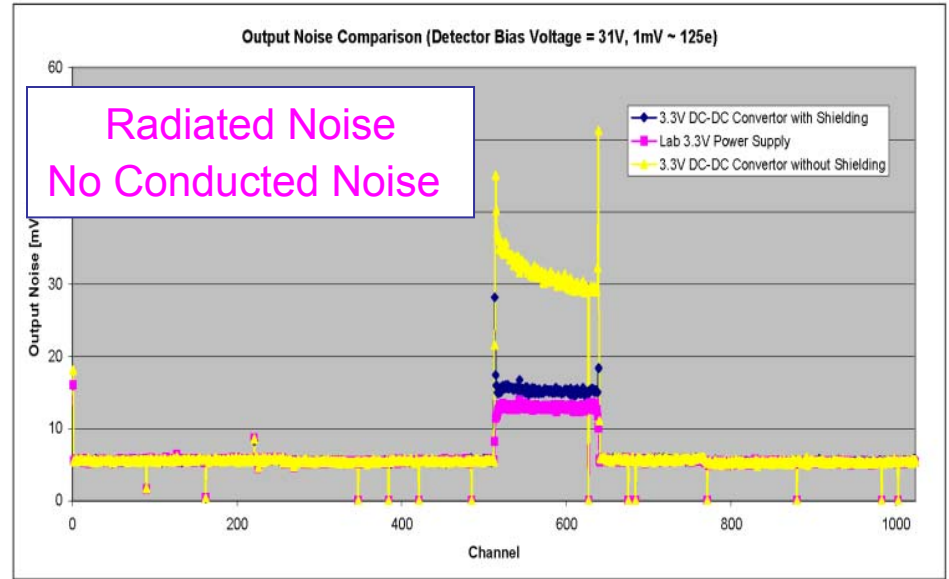

Radiated Noise
No Conducted Noise

Test @ Liverpool

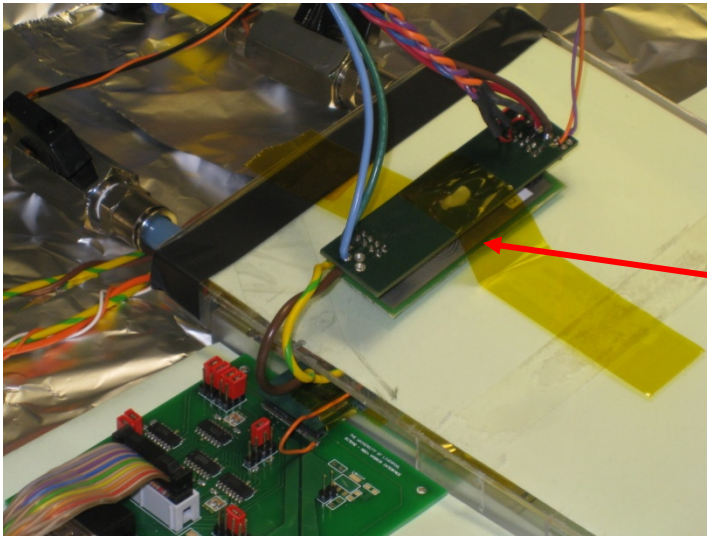

Plug in Card
1 cm from Coil
facing Sensor

20 μm Al foil
shielding

Coil Type	Power	Input Noise electrons rms
Solenoid	DC - DC	881
Solenoid	Linear	885
Spiral Coil	DC - DC	666
Spiral Coil	Linear	664

Magnetic Field Effect

7 Tesla Field Chemistry Department
Super Conducting Magnet in
Persistence Mode

Effect:

$V_{out} = 3.545$ Outside

$V_{out} = 3.546$ Edge of magnet

$V_{out} = 3.549$ Center of magnet

Change= Increased V_{out} 1 part in 900 at 7T



Ionizing Radiation Results – Commercial Converters

Device	Time in Seconds	Dose before Damage Seen (krads)	Observations Damage Mode
TPS 62110	720	40	Increasing input current
ISL 8502	730	40.6	Increasing input current
MAX 8654	850	47.2	Loss of output voltage regulation
ADP 21xx	1000	55.6	Loss of output voltage regulation
ST1510	2250	125	Loss of output voltage regulation
IR3822	2500	139	Increasing input current
EN5382	2000	111	Loss of output voltage regulation
EN5360 #3	864000 Tested in 2008	48000	MINIMAL DAMAGE
EN5360 #2	Tested in 2007	100000	MINIMAL DAMAGE

Dose rate= 0.2 Mrad/hr

5 nm Oxide DC-DC

Many more tested but similar failure-
Thin oxide converters survive > 200 Krads

Buck Regulator Efficiency after 100 Mrad dosage

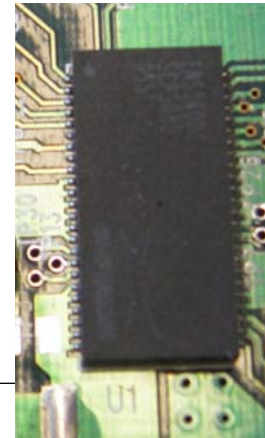
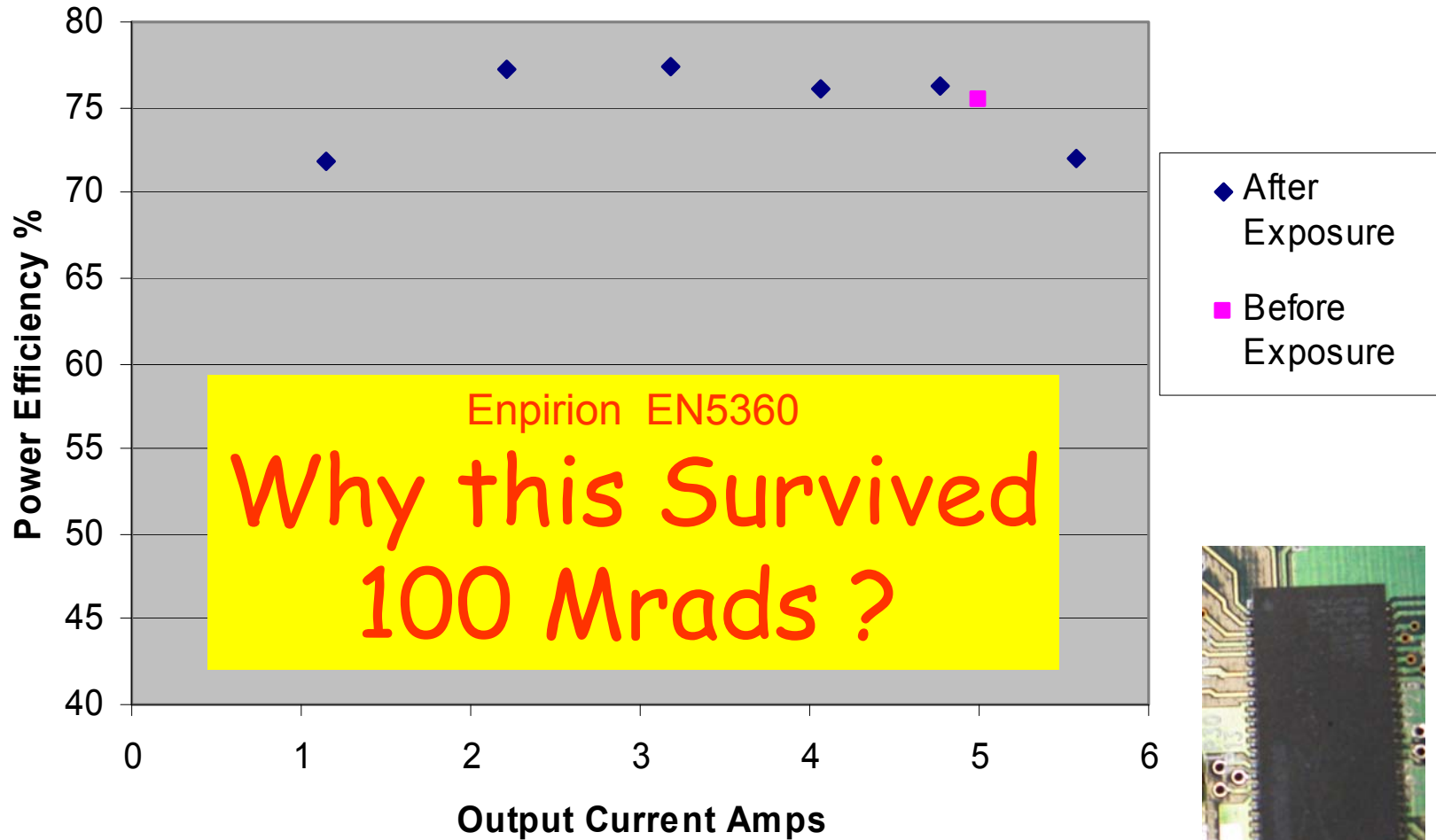

What Makes it Rad Resistant ?

Empirical Evidence: Deep submicron
But what why?

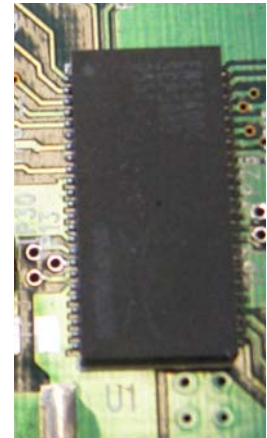
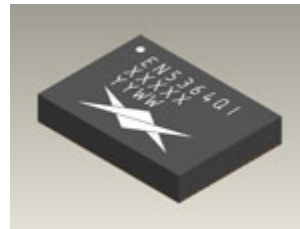

What Makes it Rad Resistant ?

We say thin Gate Oxide is a necessary Condition

Threshold Shift vs Gate Oxide Thickness

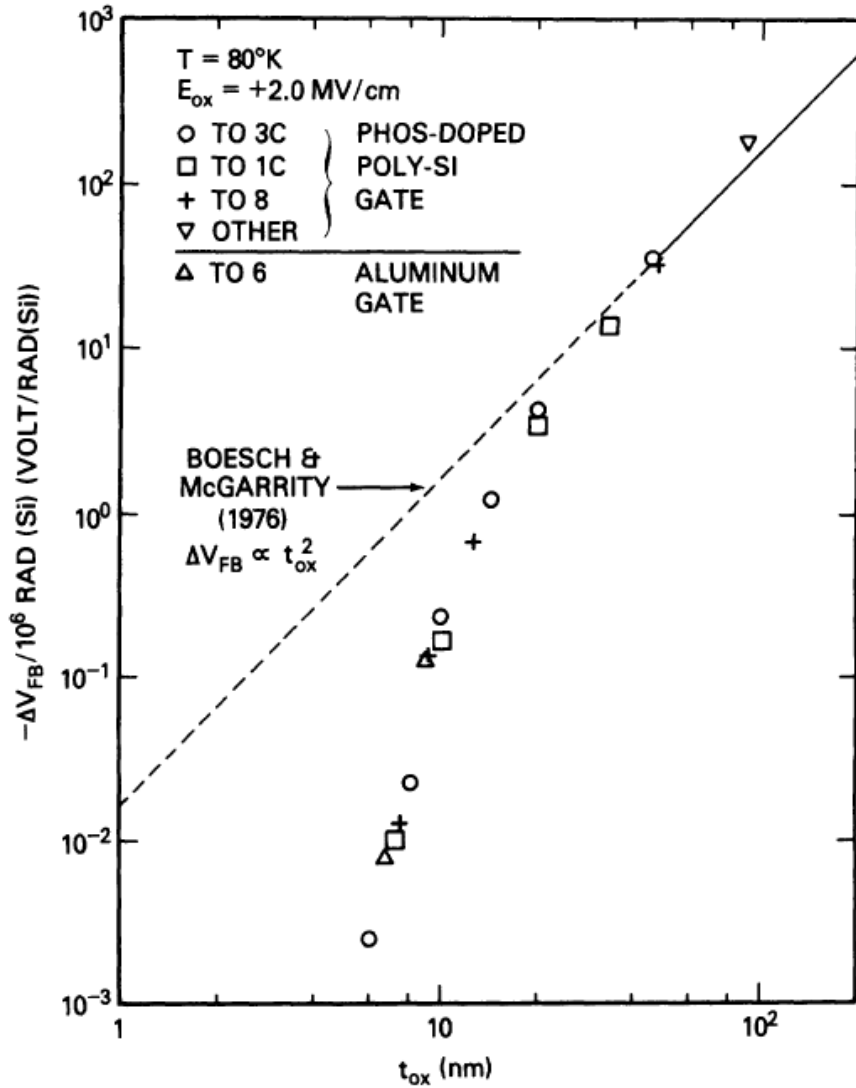

Sachs et. al. IEEE Trans. Nuclear Science NS-31, 1249 (1984)

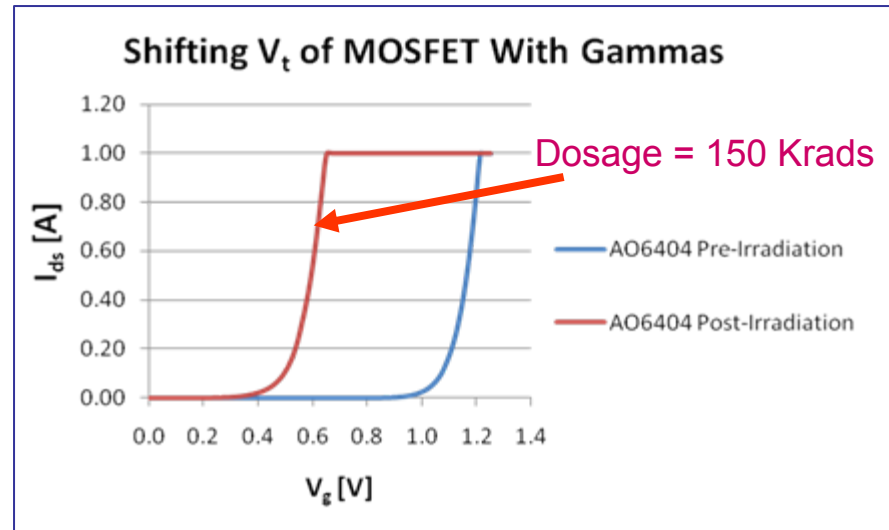
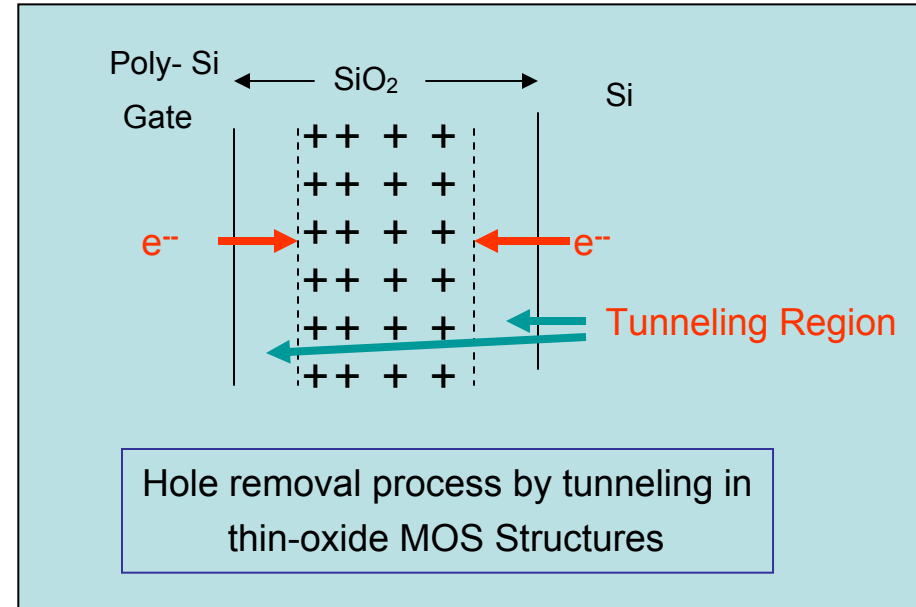

Book. Timothy R Oldham "Ionizing Radiation Effects in MOS Oxides" 1999 World Scientific

IBM Foundry Oxide Thickness

Lithography	Process	Operating	Oxide
	Name	Voltage	Thickness
<p style="color: blue; text-align: center;">CERN ASICs</p> <p style="color: blue; text-align: center;">Mantra: Deep sub micron is more rad hard</p>			nm
	Why ?		
0.25 μm	6SF	2.5	5
		3.3	7
0.13 μm	8RF	1.2 & 1.5	2.2
		2.2 & 3.3	5.2

Can We Have High Radiation Tolerance & Higher Voltage Together ???

Controller : Low Voltage

High Voltage: Switches –

LDMOS, Drain Extension, Deep Diffusion etc

>> 20 Volts HEMT GaN on Silicon, Silicon Carbide, Sapphire

LDMOS Structure
Laterally Diffused
Drain Extension

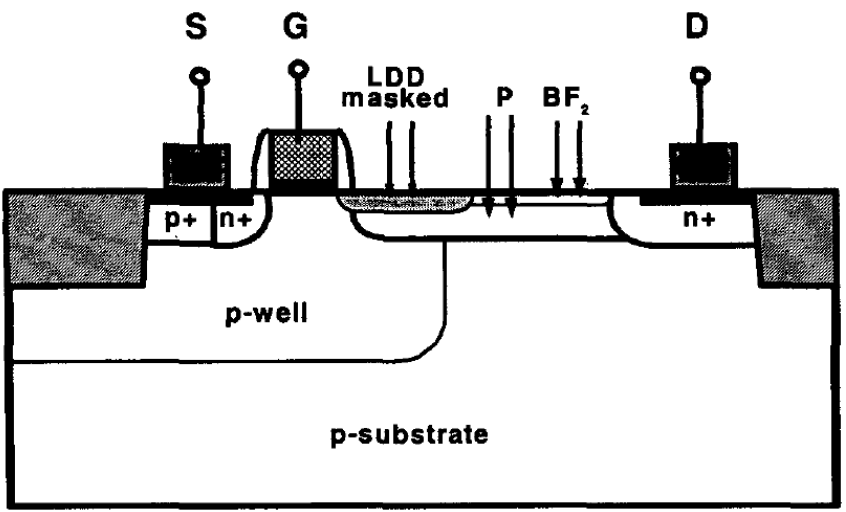

High Voltage / high Frequency
Main market. Cellular base stations

Fig.1: Schematic cross-section of the RF-LDMOS transistor.

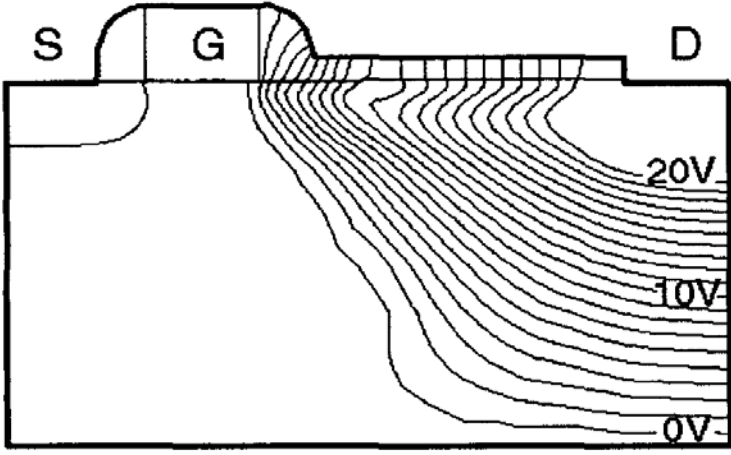

Fig.3a: Potential distribution at the highest operating voltage (20V) with $V_G=0V$ (LDMOS 3 from Table 1).

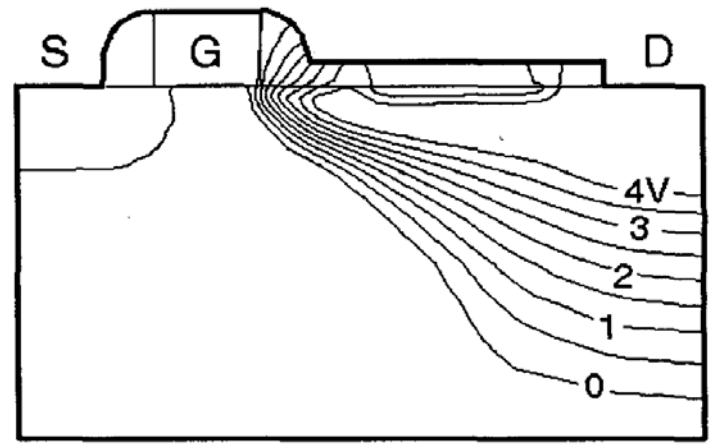

Fig.3b: Potential distribution at the lowest operating voltage (4V) with $V_G=0V$ (LDMOS 3 from Table 1).

High performance RF LDMOS transistors with 5 nm gate oxide in a 0.25 μm SiGe:C BiCMOS technology: IHP Microelectronics
[Electron Devices Meeting, 2001. IEDM Technical Digest. International](#)
2-5 Dec. 2001 Page(s):40.4.1 - 40.4.4

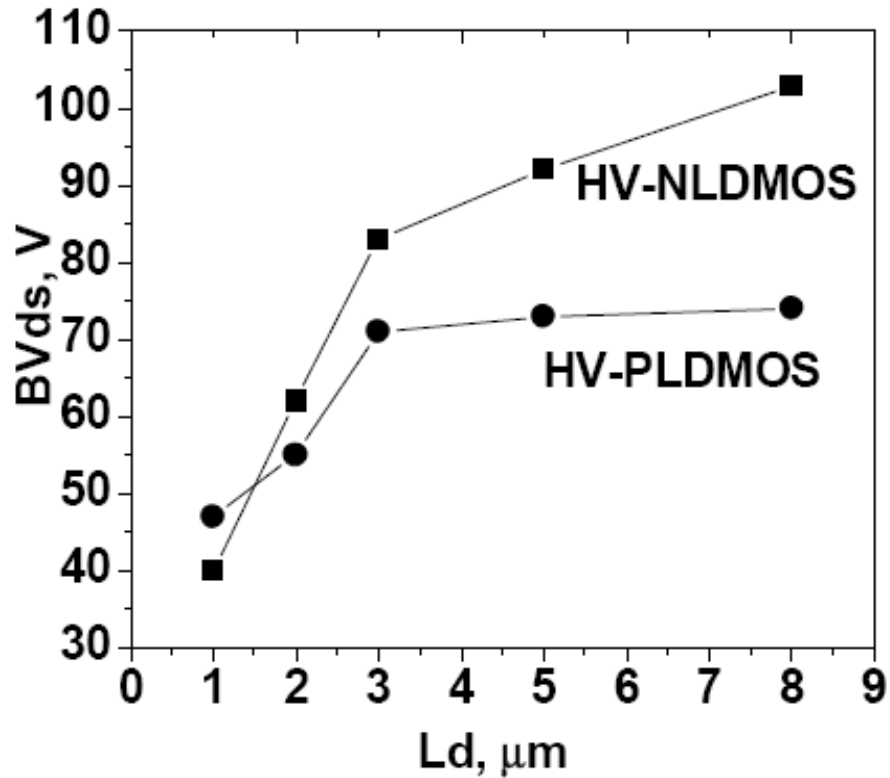

Fig. 6. BV_{dss} as function of drift length L_d. Saturation of BV_{dss} for PLDMOS due to onset of vertical break down.

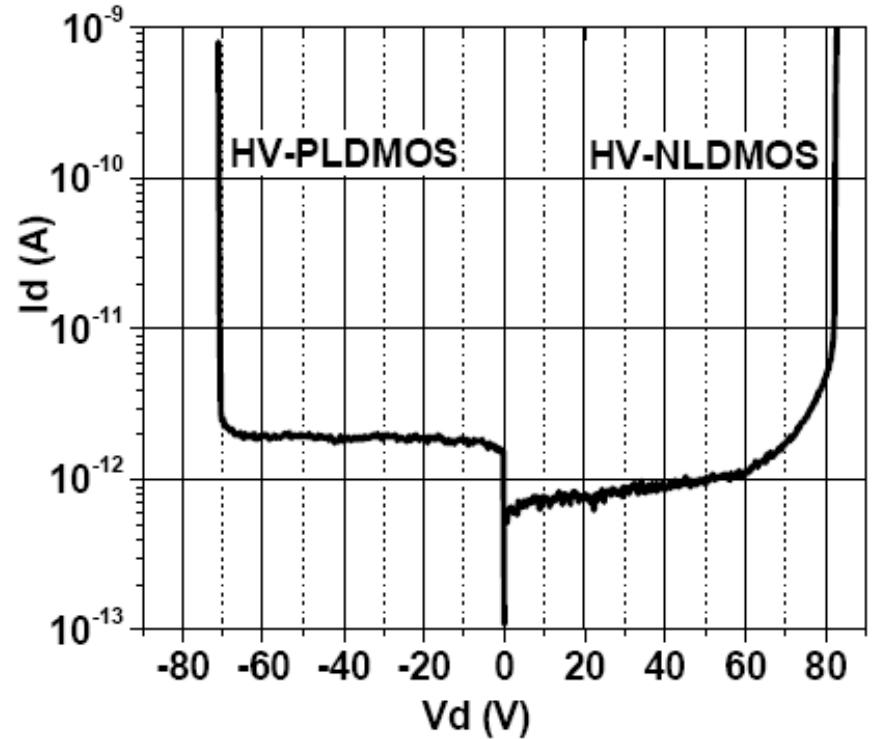

Fig. 7. Break down characteristics of PLDMOS and NLDMOS ($w = 5.6 \mu\text{m}$, $L_d = 3 \mu\text{m}$).

Thin Oxide Devices (non IBM)

Company	Device	Process	Foundry	Oxide	Dose before	Observation
		Name/ Number	Name	nm	Damage seen	Damage Mode
IHP	ASIC custom	SG25V GOD 12 V	IHP, Germany	5		Minimal Damage
XySemi	FET 2 amps	HVMOS20080720 12 V	China	7		Minimal Damage
XySemi	XP2201	HVMOS20080720 20 V	China	7		1Q2010
Enpirion	EN5365	CMOS 0.25 μ m	Dongbu HiTek, Korea	5	64 Krads	
Enpirion	EN5382	CMOS 0.25 μ m	Dongbu HiTek, Korea	5	111 Krads	
Enpirion	EN5360 #2	SG25V (IHP)	IHP, Germany	5	100 Mrads	Minimal Damage
Enpirion	EN5360 #3	SG25V (IHP)	IHP, Germany	5	48 Mrads	Minimal Damage

Necessary condition for Radiation Hardness - **Thin Gate Oxide**

But not sufficient

IHP: Epi free, High resistivity substrate, Higher voltage, lower noise devices

Dongbu: Epi process on substrate, lower voltage due to hot carriers in gate oxide

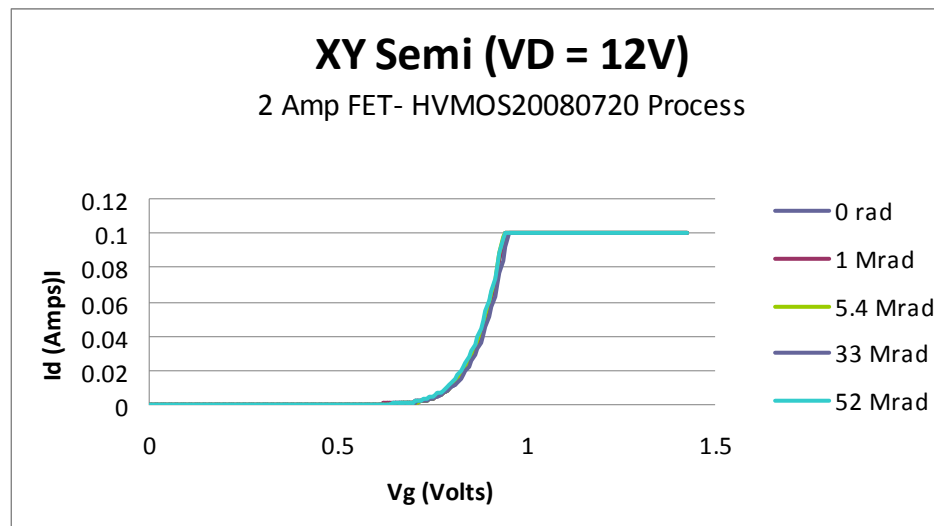
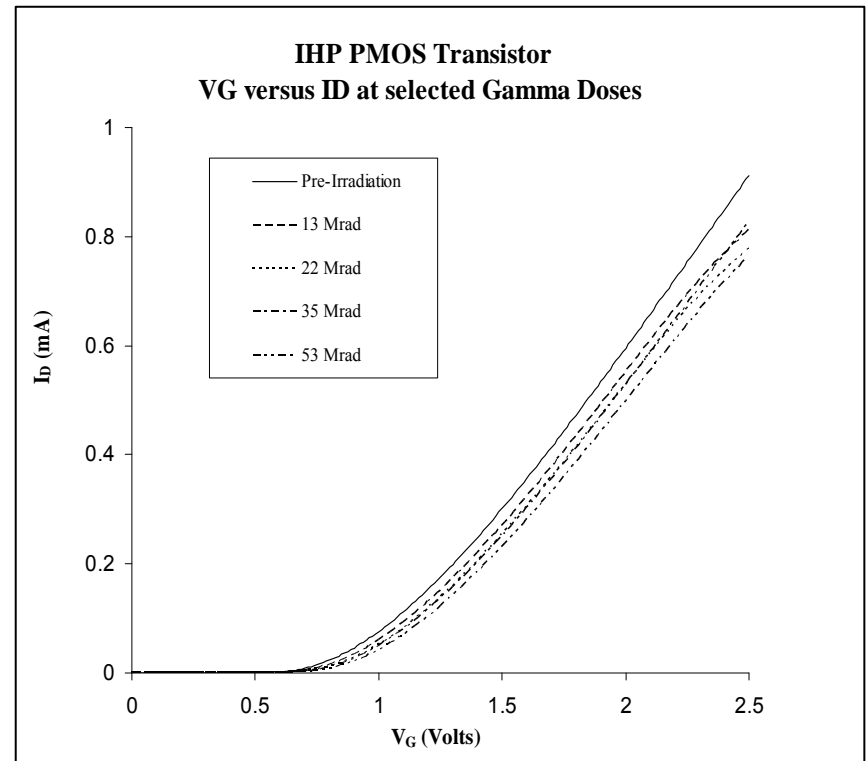
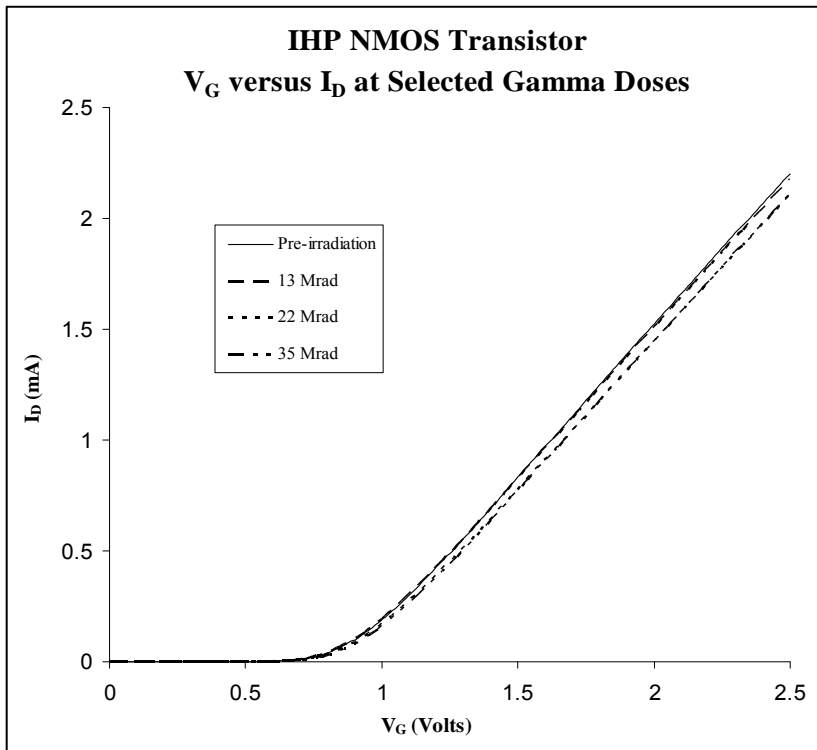

XP2201 - 20V 2A STEP-DOWN DC to DC CONVERTER

General Description

Non- Synchronous

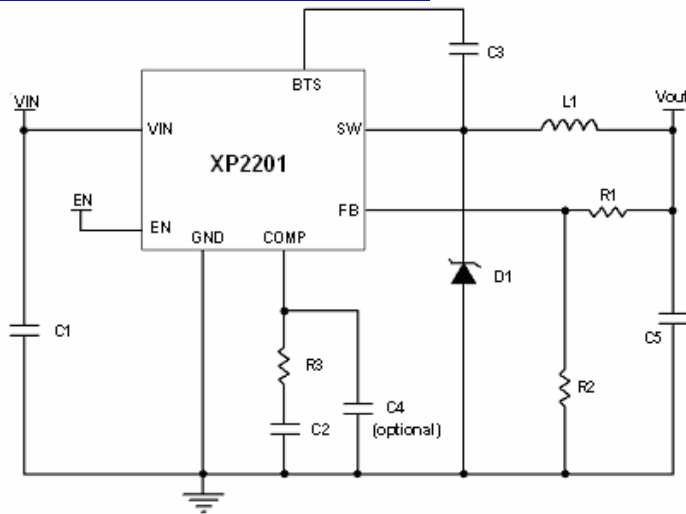

Features

- 2A Output Current
- Up to 95% Efficiency
- 4.5V to 20V Input Range
- Adjustable Output Voltage
- Fixed 400KHz Frequency
- Integrated 0.2Ω Switch
- 20uA Shutdown Supply Current
- Internal Soft Start
- Cycle-by-Cycle Over Current Protection
- Thermal Shutdown
- Programmable Under Voltage Lockout
- Operating Temperature: -40°C to +85°C
- Available in an 8-Pin SO Package

Replacement for LHC4913:

LHC Radiation Hard LDO
Made by ST Microelectronics

Use with Ferrite Coil

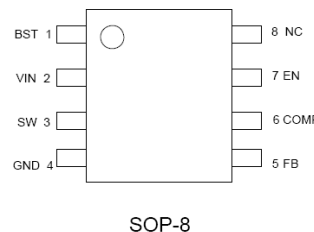

Engineering Samples
1Q2010

GaN HEMTs Why of Interest?

- High voltage and current rating
- Very high switching frequency (> 1 GHz range)
- Depletion mode are radiation Hard (details follow), Enhancement mode devices not yet available

GaN for Power Switching

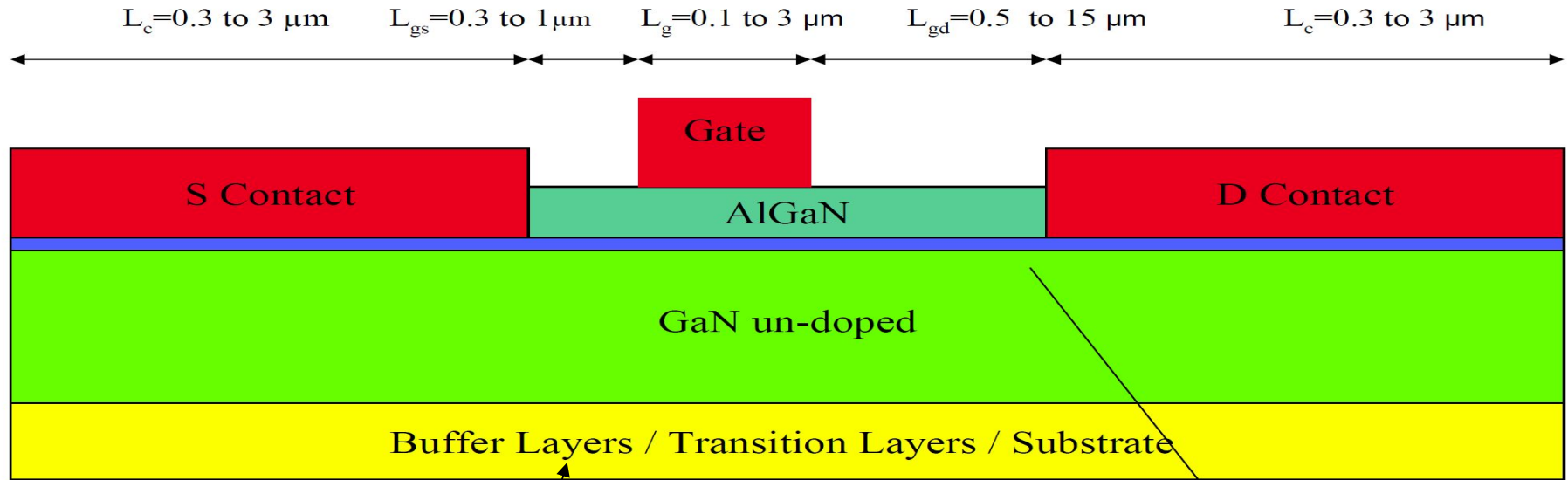

For Lattice mismatch GaN & Silicon

Piezoelectric effects
create 2 DEG electron
sheet $n_s = 10^{13} \text{ cm}^{-2}$

No Gate Oxide
High Dielectric strength
High Thermal conductivity

GaN HEMT

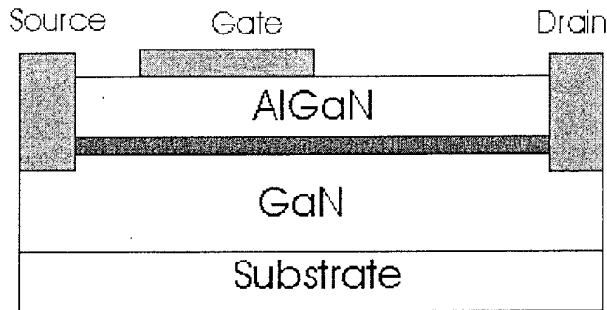

- Low on-resistance due to high Channel mobility ($1500 \text{ cm}^2/\text{V}\cdot\text{s}$) and sheet electron density ($1 \times 10^{13} \text{ cm}^{-2}$)
- High gate leakage current (reduced by hybrid MOS-HEMT structure)
- Small conduction band offset between AlGaN and GaN

Depletion Mode
Normally ON

GaN MOSFET

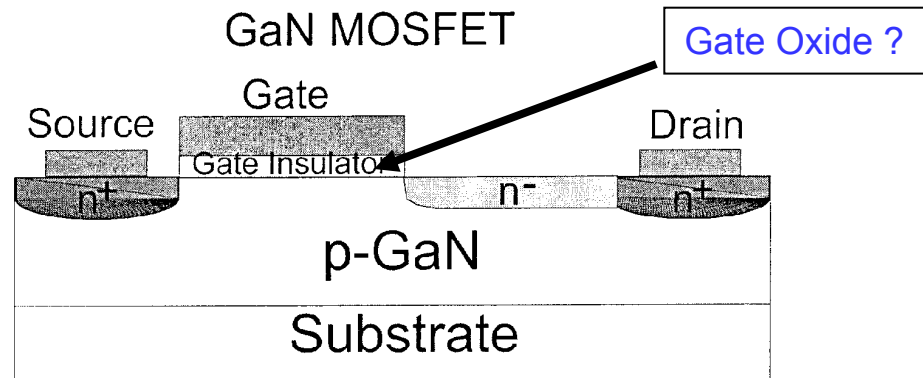

- Inversion-mode, normally-off operation
- Blocking voltage controlled by dopants incorporated by epi-growth or ion-implantation
- Low gate leakage current

Enhancement Mode
Normally OFF

Gallium Nitride Devices under Tests

RF GaN 20 Volts & 0.1 amp

- ❖ 8 pieces: Nitronex NPT 25015: [GaN on Silicon](#)
- ✓ Done Gamma, Proton & Neutrons
- ✓ 65 volts Oct 2009

- ❖ 2 pieces: CREE CGH40010F: [GaN on siC](#)

- ❖ 6 pieces: Eudyna EGNB010MK: [GaN on siC](#)
- ✓ Done Neutrons

Switch GaN

- ❖ International Rectifier [GaN on Silicon](#)
[Under NDA](#)

Gamma: @ BNL
Protons: @ Lansce
Neutrons: @ U of Mass Lowell

Plan to Expose same device to
Gamma, Protons & Neutrons
Online Monitoring

Bias during Radiation

Max operating V & I Limit Power by duty cycle

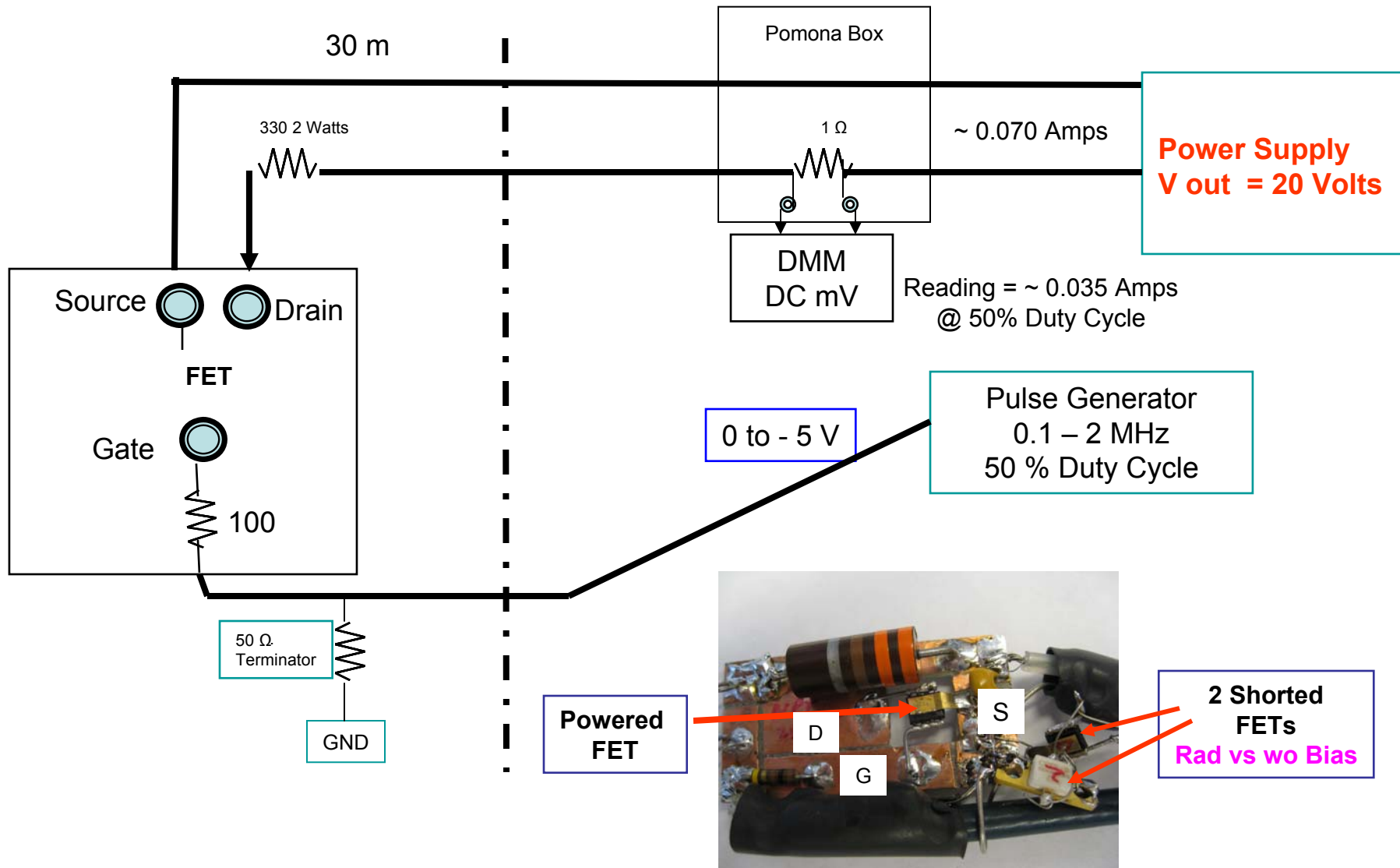

Nitronex 25015

Serial # 1

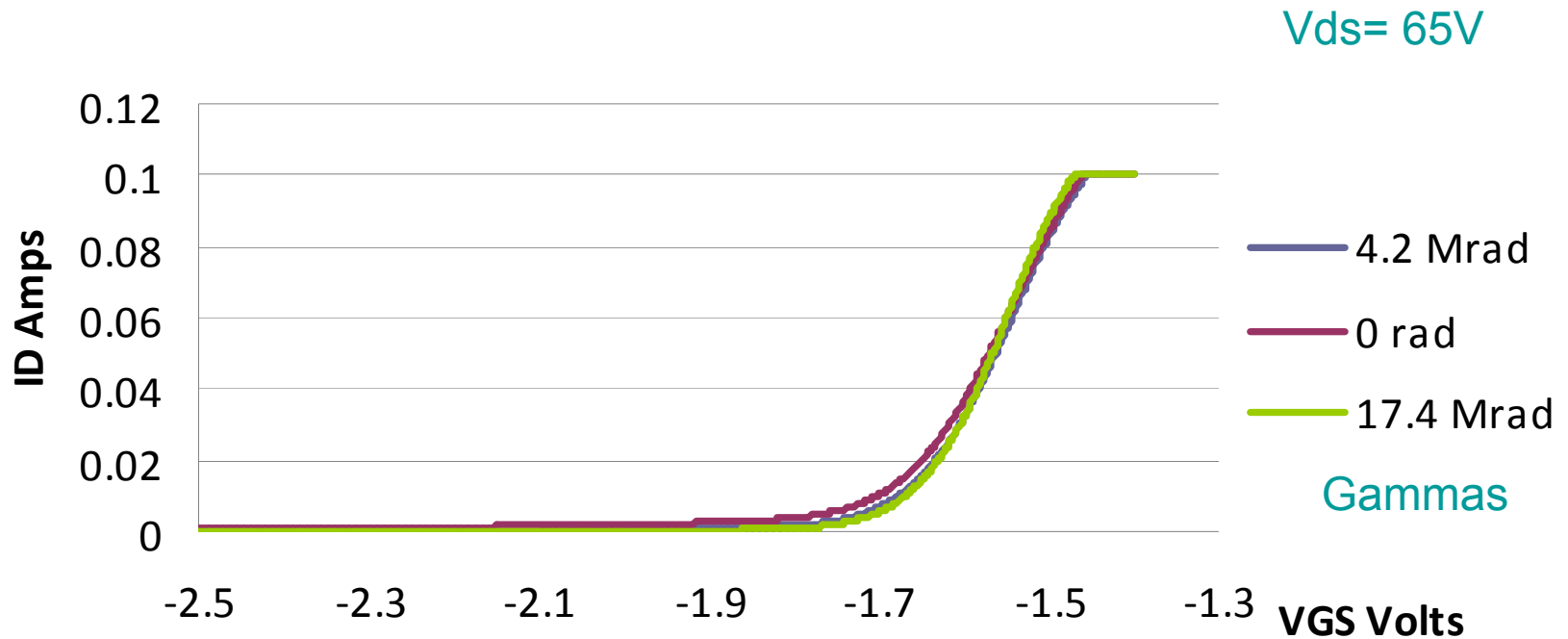

200 Mrads of Protons had no effect – switching 20 V 0.1 Amp
Parts still activated after 7 months

Eudyna GaN HEMT Before and After Gamma Irradiation $V_{ds} = 1\text{ V}, 10\text{ V}$

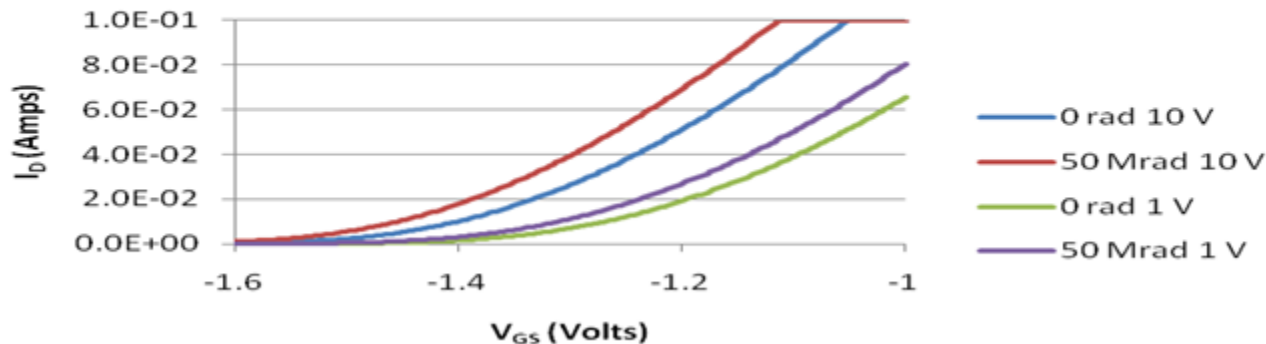

Our next IEEE TNS
Paper shall summarize
work to date

Eudyna GaN HEMT Before and After Neutron Irradiation

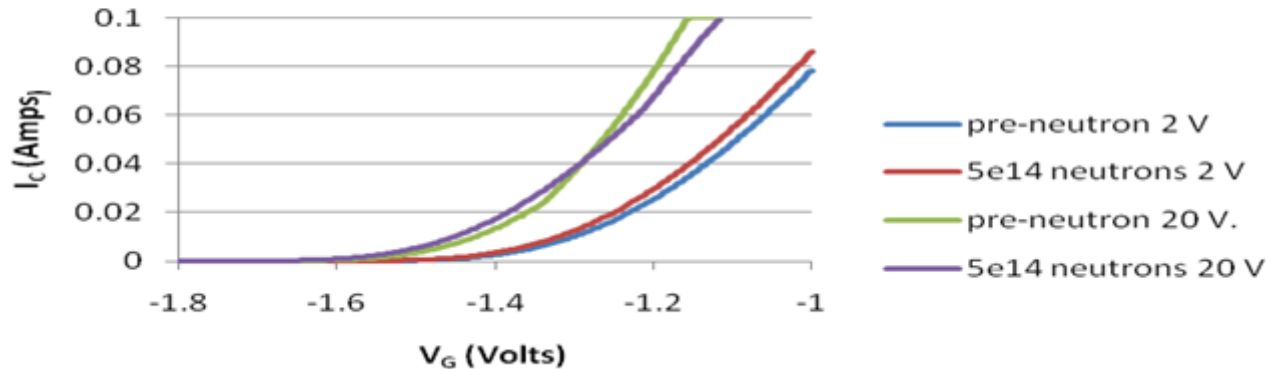

Proton Test

Proton Fluence = 1×10^{15} p/cm² over a period of about 24 hours.

Biased = 65 volts switching @ 1MHz

Average current = 65 mA limited by Load resistor . No change in current.

6 times Higher Frequency over Si Solution with similar efficiency !

Silicon based POL :
15 mm x 15 mm

1MHz, 10A



6MHz, 12A

IR GaNpowIR
Gen 1.1 Solution:
6 mm x 9 mm....
75 +% Smaller!

We had a later version
of the Engineering sample

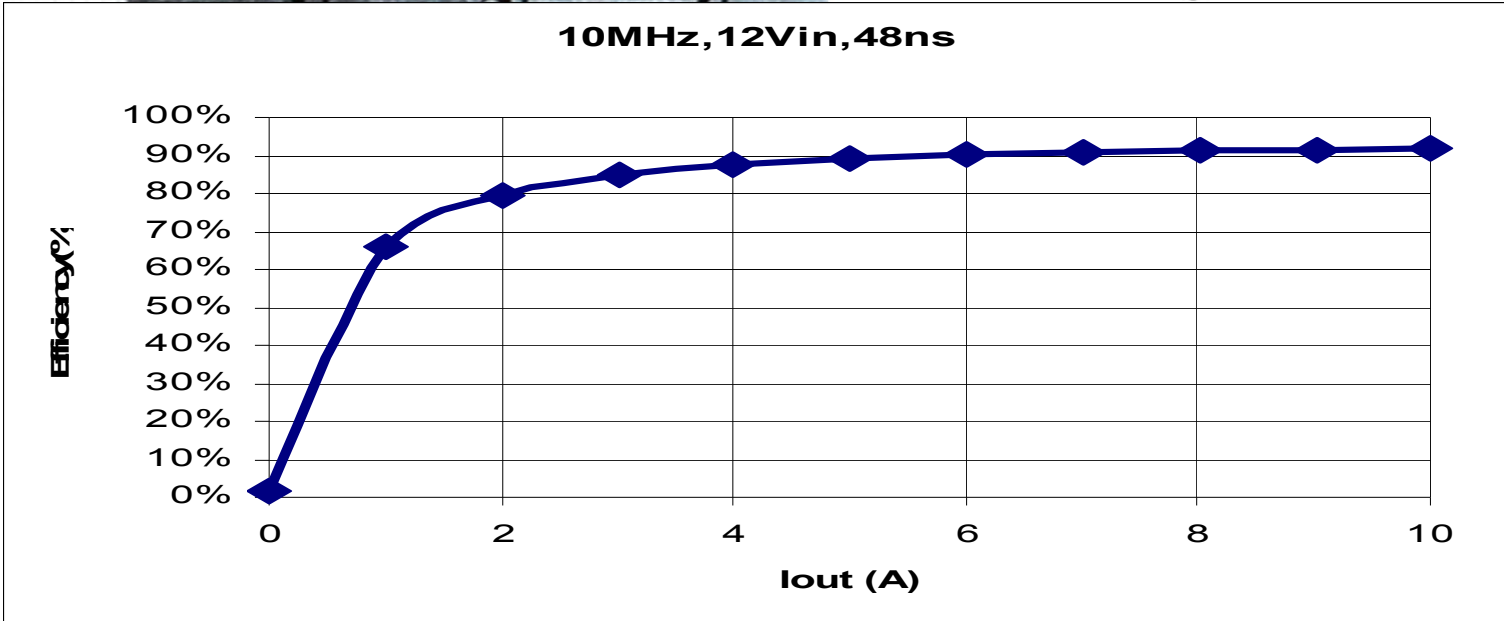

PSOC: Power Supply On a Chip

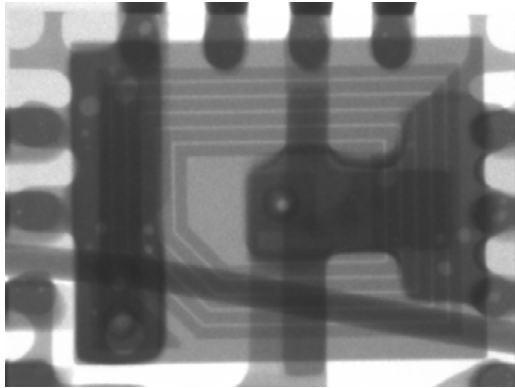

EN5382 with 30AWG

Spiral with FeCo Coating

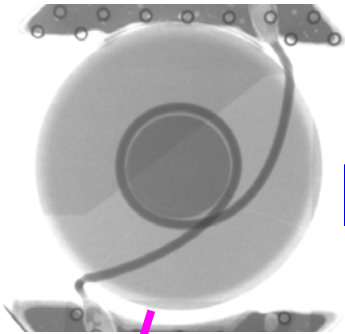

1 turn around slug

5 MHz

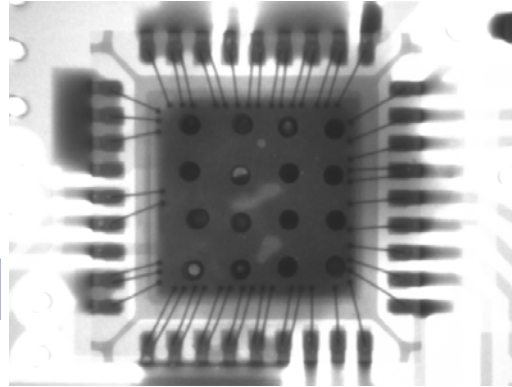

MAX8654 Monolithic

No Inductors

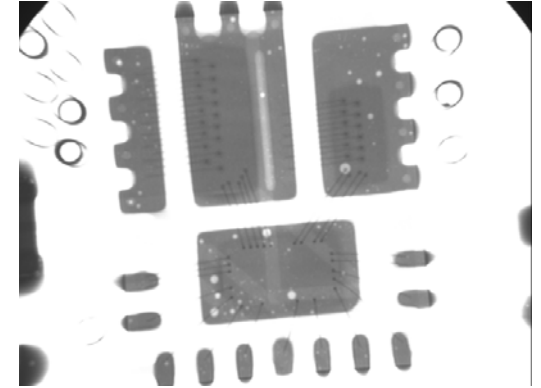

IR8341 MCM

No Inductors

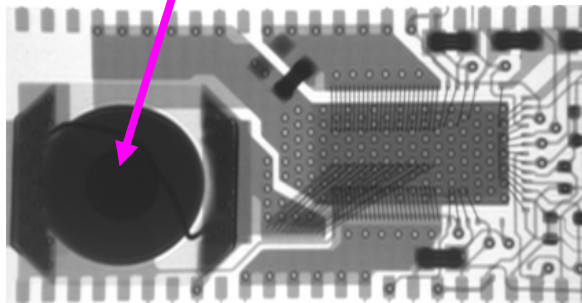

EN5360

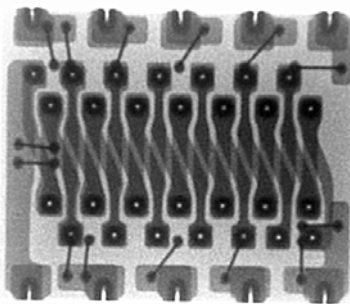

Fuji FB6831J

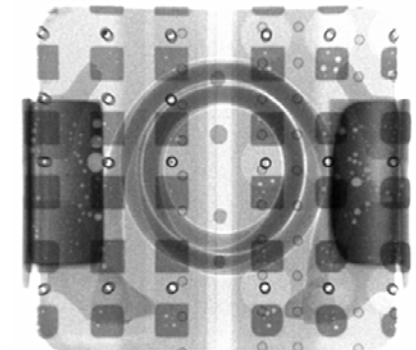

LT4602

Look Inside Packages with 90 KV X-Rays

PSOC: Power Supply On a Chip

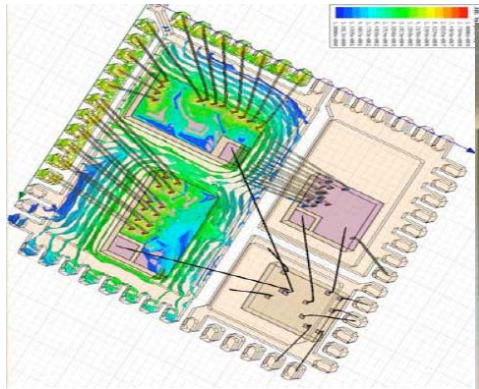

FAN5009 8 x 8 mm MCM
 12 V > 1.2 V = 88.5% @ 30 A

National: LMZ Package 10 x14 x5 mm 20/42 V > 1.2V 5 A

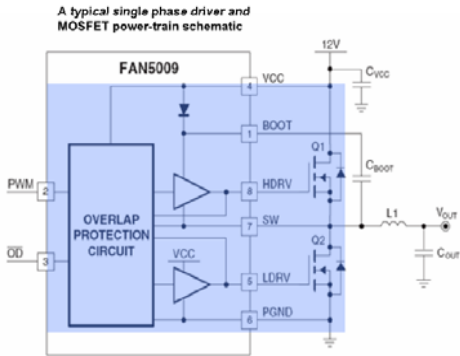
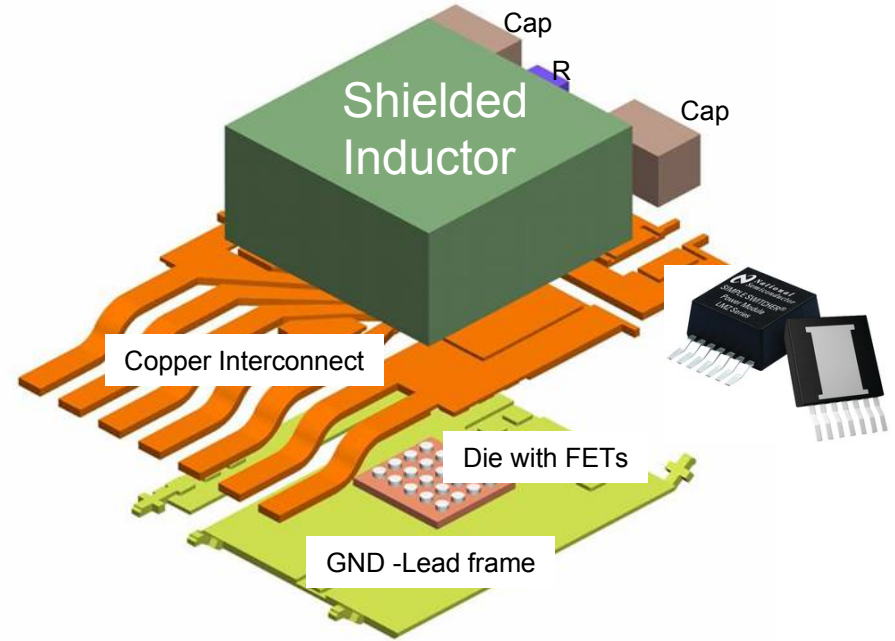

Active Layer using Flip MOS Pair

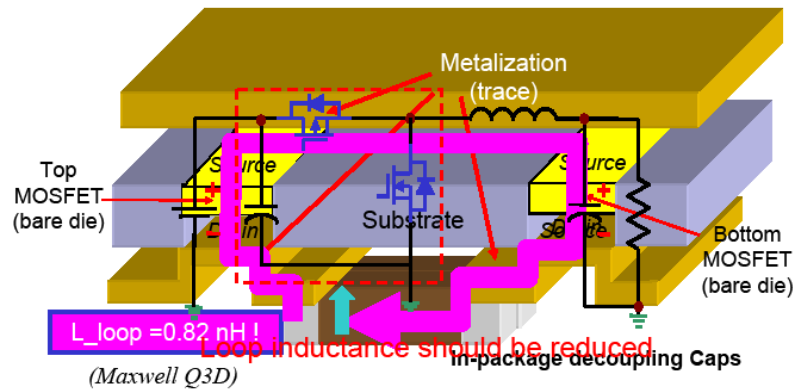

❖ Embedding the flipped devices allows for smallest loop inductance and for layering of components on top and bottom

PSOC: Power Supply On Chip

PSMA: Road Maps

Power Supply Manufacturer Association

Yale University is member

What is happening outside HEP ?

Server Power System Distribution from IBM

1. AC Distribution - 208/230/115V

- o Servers, Blade Servers, Workstations

2. 12V DC Distribution

- o Blade Server Chassis, Low end and Midrange Servers, Workstations

3. 48V Distribution in a Rack

- o High End Server Applications

4. 350V DC Distribution in a Server Rack or a Rectifier Cabinet

- o Main Frame Servers

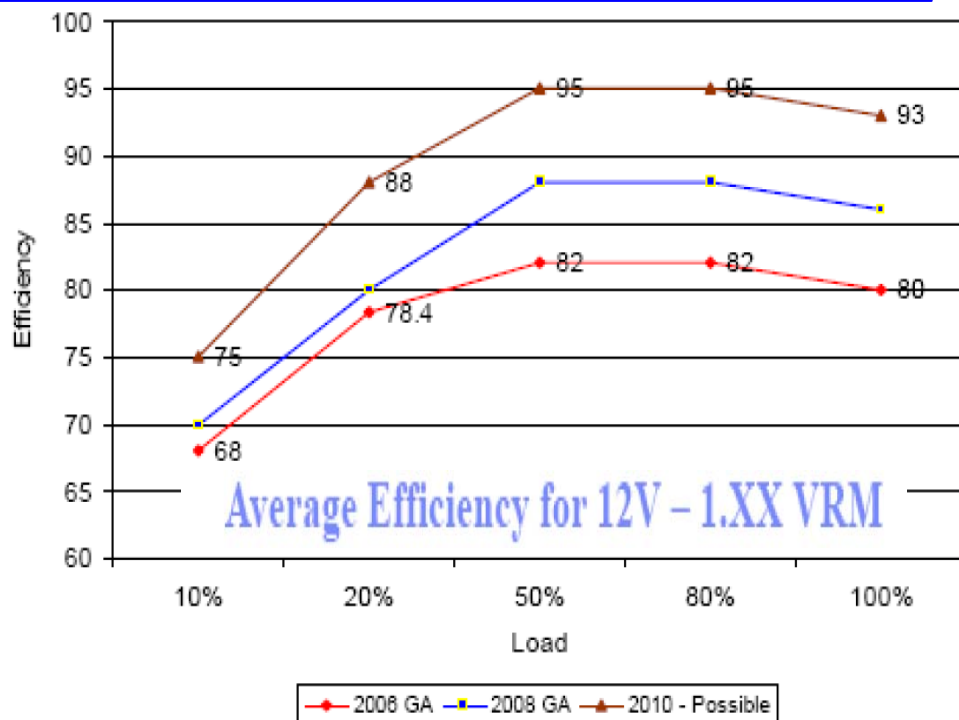

International Workshop on Power Supply On Chip

Sept 22nd - 24, 2008

Cork, Ireland

Potential LV DC-DC Power Stage Roadmap

Optimized Performance – Without tradeoff

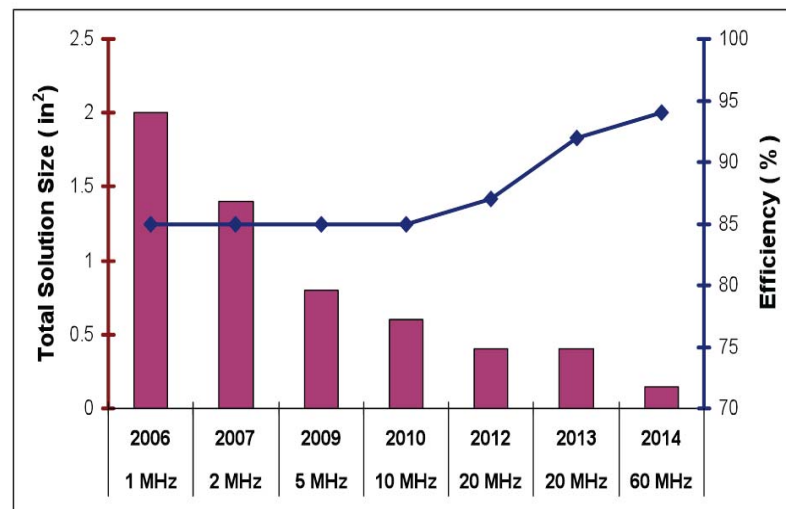

12Vin, 1.2Vout, 100A Based on Circuit Simulation

Is there a Commercial product available ?

Yes = It is the EN5360

- ❖ Satellite folks are using it now
- ❖ sLHC Levels – 100 Mrads
- ❖ Use for voltage ratio = 4
- ❖ Work at Super LHC levels for Tracker
- ❖ 5.5 V in > 1.3 out
- ❖ Enpirion is still supplying these to a very large customer
- ❖ IHP foundry will make it for many years.
- ❖ Can purchase in Die form for use with Air coil

For Purchasing EN5360:

Steve Robb (908) 894 -6083 srobb@enpirion.com

Tom Howell (908) 894-6029 thowell@enpirion.com

Some Random Remarks

- Learned from commercial devices, companies & power conferences
- Can get high radiation tolerance & higher voltage simultaneously
- High frequency > smaller air coil > less material
- Goal: ~20 MHz buck, MEM on Chip *size 9 mm x 9mm*
- Power SOC: MEMs air core inductor on chip
- Will study feasibility of 48 / 300V converters
- Irradiations:
 - Important to run @ max operating V & I.
 - Limit power dissipation by switching duty cycle
 - Use online monitoring during irradiation for faster results
- Yale Plug Cards can be loaned for evaluation
- Collaborators are Welcome

Conclusions

- The power distribution needs of HEP detectors require new solutions/technologies to meet power and environmental requirements.
- DC/DC (Buck) Converters are potential solutions for these needs.
- The environment requires that these converters operate in high radiation environments and high magnetic fields at high switching frequencies in a small size/mass package.
- Target technologies for the switches are radiation hard GaN and 0.25 μm LDMOS. High frequency controllers driving small sized nonmagnetic/air core inductors are also required.
- Many of these components have been tested and now need integration to produce a working prototype. This is the next step in our R&D program.

A polar bear stands upright on a vast, snowy, and icy landscape. The bear is positioned in the center-left of the frame, casting a long shadow to its left. The ground is covered in snow and ice, with numerous footprints leading away from the bear. Two large, dark, irregularly shaped melt holes are visible in the snow. The overall scene is desolate and cold, emphasizing the isolation of the environment.

Working on Power Supply
Is not Glamorous

Top of the World is Cool but lonely !

More Details: www.Yale.edu/FASTCAMAC click on DC-DC

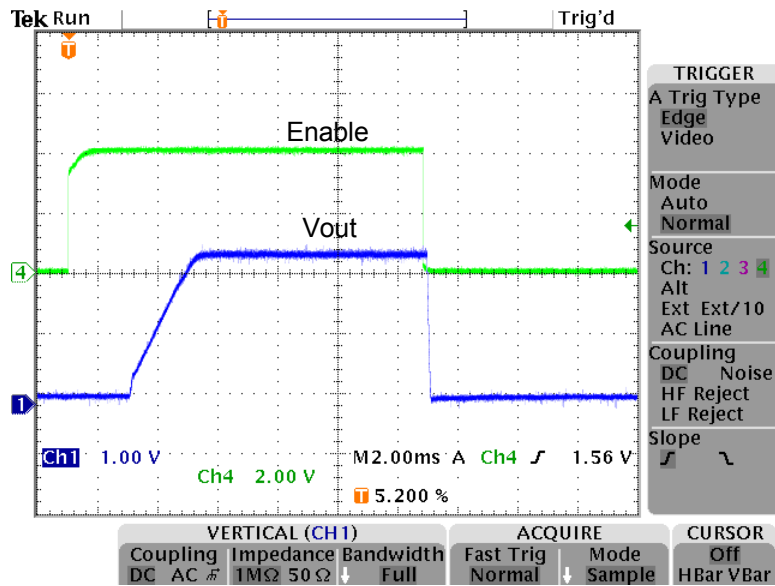
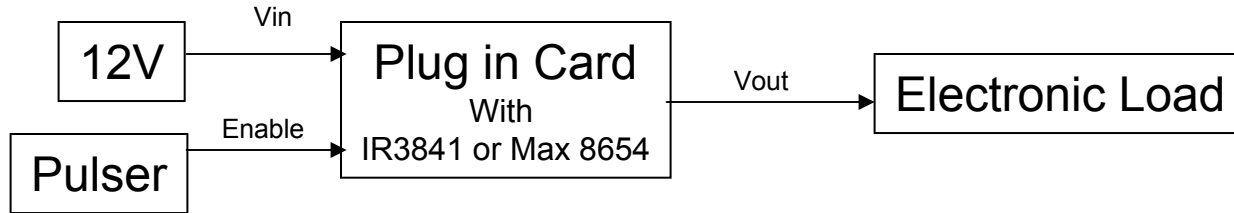

IR8431 with 3 amp Load
 $V_{in} = 12\text{ V}$
 $V_{out} = 2.5\text{ V}$
 Load = 3 amps (Electronic)

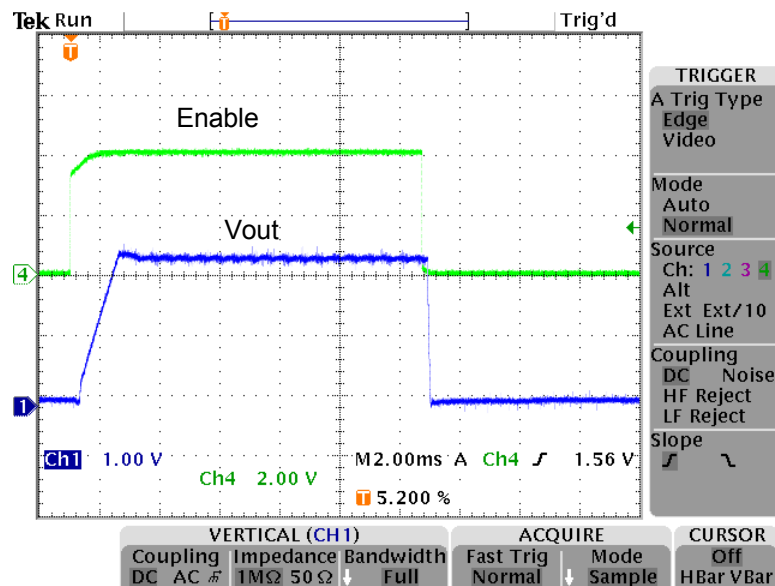

MAX8654
 $V_{in} = 12\text{ V}$
 $V_{out} = 2.5\text{ V}$
 Load = 3 amps (Electronic)

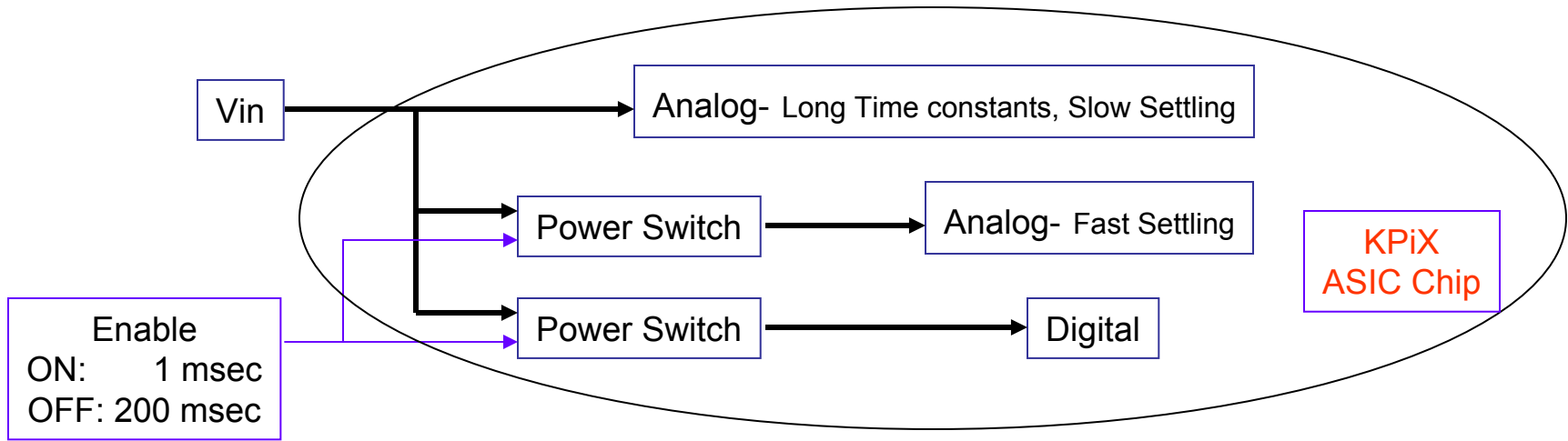

Simulation with a National Semiconductor Buck Converter

- ~ 1 MHz
- Load 3 amps Type R, Electronic, CMOS ASIC
- $V_{in} > 12\text{ V}$
- $V_{out} = 1.2 / 2.5\text{ V}$
- Settling Time on/off, Voltage/ Current Loop?, Caps, Stability, Ripple/Noise

Circuit for simulation of converter settling times